

ARES

ARES S.r.l.
Zona artigianale "Gli Ulivi"
Sestino (AR)

www.aresmobilificio.it

COD.0WMMBI013BLD

- Ⓘ ISTRUZIONI DI MONTAGGIO
- ⒼⒷ ASSEMBLING INSTRUCTIONS
- ⒻⓇ NOTICE DE MONTAGE
- ⒺⓁ NAVODILA ZA MONTAŽO

- Ⓓ MONTAGEANLEITUNG
- ⒺⓈ INSTRUCCIONES DE MONTAJE
- Ⓐ INSTRUÇÕES DE MONTAGEM
- ⒻⓇ UPUTE ZA MONTAZU

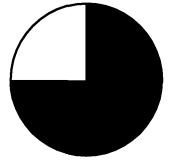
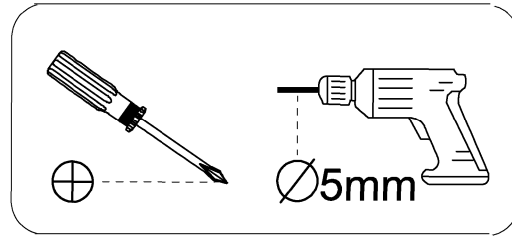
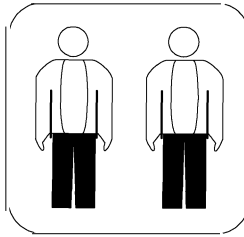
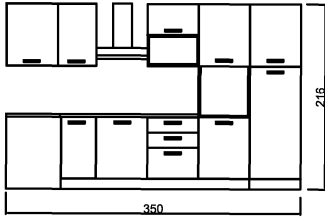

120 MIN

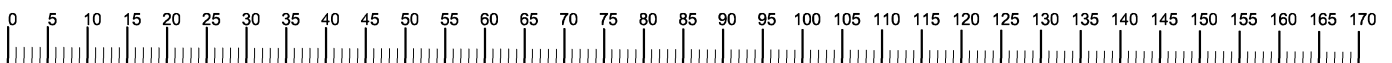
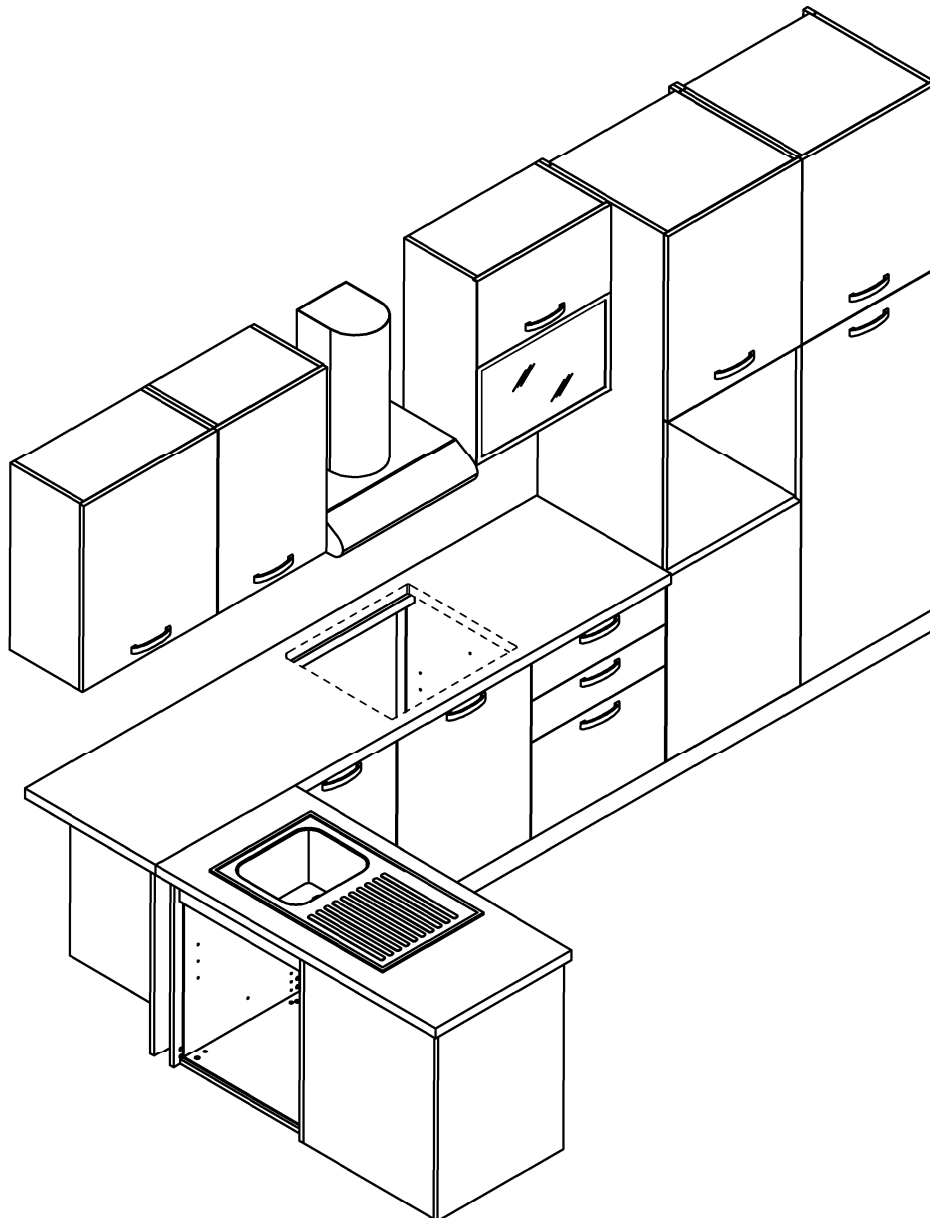

Française – Suisse

CONSEILS DE MONTAGE

1. Bien étudier la notice de montage;
2. Repérez les pièces constituant votre meuble;
3. Regroupez et contrôlez la quincaillerie;
4. Munissez-vous de l'outillage nécessaire;
5. Aménagez-vous une zone de montage;
6. Procédez au montage.

CONSEILS D'ENTRETIEN

1. Dépoussiérez soigneusement;
2. Humecter un chiffon doux et propre d'eau légèrement savonneuse (ou détergent)

Ne jamais forcer les assemblages
Resserrez les vis après quelques temps d'usage
Garder votre notice de montage
Si une pièce devait a manquer, le plus simple est de contacter votre magasin directement
Le poids maximum autorisé sur les boîtes de tiroir est de 10 kg

Ne jamais utiliser de produits abrasifs:
poudre, laine d'acier, solvants

English

ASSEMBLING ADVICE

1. Study careful the assembly instructions;
2. Characterize pieces that form the furniture;
3. Group and control the ironware;
4. Take the necessary tools for the assembly;
5. Prepare an assembly zone;
6. Proceed with the assembly.

MAINTENANCE ADVICE

1. Dust accurately;
2. Damp a cleaned and soft cloth with water and little detergent.

Never force the assemblages
Screw the screws after a long period
Conserve the assembly instructions
If one or more pieces are missing, please contact the store
Maximum weight allowed on drawer boxes is 10kg.

Do not use abrasive products: powder, steel wool, solvents

Italiano – Svizzera

CONSIGLI DI MONTAGGIO

1. Studiare bene le istruzioni di montaggio;
2. Controllare che tutti i pezzi che costituiscono il mobile siano presenti;
3. Raggruppare e controllare la ferramenta;
4. Munirsi degli utensili necessari al montaggio;
5. Allestire una zona di montaggio;
6. Procedere al montaggio.

CONSIGLI PER LA MANUTENZIONE

1. Spolverare accuratamente;
2. Inumidire con acqua leggermente insaponata uno straccio morbido e pulito.

Non forzare mai gli assemblaggi
Stringere le viti dopo un periodo d'uso
Conservare le istruzioni di montaggio
Se un pezzo dovesse mancare o essere rotto, contattare il punto vendita
Il peso massima supportato dai cassetti è di 10kg.

Non utilizzare mai prodotti abrasivi:
polvere, lana di acciaio, solventi

Deutsch – Schweiz

MONTAGE ANLEITUNG

1. Die Montageanleitung genau durchlesen;
2. Die Einzelteile des Möbels stück ermitteln;
3. Die Beschläge zusammenlegen und prüfen;
4. Das Notwendige werkzeug zurechtlegen;
5. Einem Montagebereich freimachen;
6. Das Möbels stück zusammenbauen.

PFLEGEHINWEISE

1. Sorgfältig entstauben;
2. Mit einem weichen, sauberen und feuchtem Tuch und leichter selfentaue reinigen

Niemals die Verbindungen zu stark anziehen
Die Schrauben nach Lang Zeit des Gebrauchs erneut festziehen
Die Montageanleitung gut aufbewahren
Wenn ein Teil fehlen, ist Sie das beste Verständigungsmittel mit Ihrem Geschäft
Das maximale Gewicht auf Schubladenkästen erlaubt ist 10 kg

Benutzen Sie keine Scheuermittel wie
Pulver, Stahlwolle, Lösungsmittel

Español

CONSEJOS PARA EL MONATJE

1. Estudie atentamente el manual de montaje;
2. Localice las piezas que constituyen su mueble;
3. Reuna y contrle los tornillos;
4. Equipese de las herramientas necesarias;
5. Prepare una zona de montaje;
6. Realice el montaje.

CONSEJOS PARA EL MANTENIMIENTO

1. Despolvorear cuidadosamente;
2. Humedecer un pano suave y limpio con agua ligeramente enjabonada.



No fuerce nunca en las uniones
Apriete los tornillos despues de cierto tiempo de utilizacion
Conserve su manual de montaje
Si faltara una pieza, seia la manera mas facil de comunicar con la tienda
El peso máximo permitido en las cajas de cajón es de 10 kg

No use nunca productos abrasivos tales como: polvo de limpiar, lana de acero, solventes.

Portugues

CONSELHOS DE MONATAGEM

1. Estuda bem as instruções de montagem;
2. Junta as peças que constituem o seu móvel;
3. Reagrupa e controla a quinquilharia;
4. Equipa-se da ferramenta necessária;
5. Cria-se uma zona de montagem;
6. Proceda á montagem.

CONSELHOS DE MONTAGEM

1. Eliminar bem o po;
2. Umedecer um pano suave e limpo con agua e um pouco de sabao.



Nunca esforçar as montagem
Apertar os pafusos após un tempo de utilização
Guardar as instruções de montagem, si faltara alguna pieza, lo mas aconsejable es contactar con la tienda
O peso máximo permitido em caixas de gaveta é de 10 kg

Nunca utilizar productos abrasivos pos, la de aço, solventes

Hrvatski

SAVJETI ZA MONTAZU

1. Porucite pazljivo upute za montazu;
2. Prekontrolirajte po uputama da li imate sve dijelove;
3. Prekontrolirajte da li imate sve vijke, matice i ostale metalne dijelove;
4. Osigurajte potreban alat za sastavljanje;
5. Oslobodite odgovarajuci prostor za montiranje;
6. Ukoliko ste provjerili sve gore navedeno mozete zapoceti montazu.

SAVJETI ZA ODRZAVANJE

1. Uklanjajte redivito prasinu i necistoce;
2. Cistite uvijek s mlo vode i blagog deterdzenta te mekom i cistom krpom.



Prilikom montiranja, nemojte nasilno pokušavati spojiti dijelove
Odvijati vijke nakon duzeg stajanja montiranog proizvod
Ukoliko Vam nedostaje koji dio, molimo Vas kontaktirajte trgovinu u kojoj ste namjestaj kupili
Ladica ima nosivost od maksimalnih 10kg

Nemojte koristiti abrazivne krpe, pudere, matalnu vunu ili sredstva koja mogu otopiti površinu namjestaja

SLOVENŠČINA

NAVODILA ZA MONTAŽO

1. Pozorno preberite navodila za montažo;
2. Določite posamezne dele pohištva;
3. Preverite, ali imate vse vijake, matice in ostale kovinske dele;
4. Pripravite potrebna orodja;
5. Pripravite in počistite prostor, kjer boste pohištvo sestavljali;
6. Sestavite pohištvo.

NAVODILA ZA NEGO

1. Redno brišite prah.
2. Očistite z mehko, čisto in vlažno krpo ter uporabite malo milnice.



Delov ne zategujte preveč.
Po daljšem času ponovno zategnite vijake.
Navodila za montažo hranite na varnem mestu.
Če kakšen del manjka, kontaktirajte prodajalno, v kateri ste pohištvo kupili.
Predali imajo največjo nosilnost 10 kg.

Ne uporabljajte abrazivnih krp, praškov, jeklene volne ali sredstev, ki lahko raztopijo površino pohištva.



БЪЛГАРСКИ

СЪВЕТ ЗА МОНТАЖ

1. ПРОУЧЕТЕ ВНИМАТЕЛЮ ИНСТРУКЦИИТЕ ЗА СГЛОБИКА;
2. ПРОВЕРЕТЕ ДАЛИ ВСИЧКИ ЧАСТИ, КОИТО СЪСТАВЛЯВАТ МЕБЕЛИТЕ ПРИСЪСТВАТ;
3. ПРОВЕРЕТЕ ДАЛИ ИМАТЕ ВСИЧКИ В ВИНТОВЕ, ГАЙКИ И ДРИГУ МЕТАЛНИ ЧАСТИ;
4. ОСИГУРЕТЕ НЕОВХОДИМИТЕ ИНСТРУМЕНТИ ЗА СГЛОБИАВАНЕ;
5. ОСВОБОДЕТЕ ПОДХОДЯЩО МЯСТО ЗА МОНТАЖ;
6. ПРОДЪЛЖЕТЕ КЪМ СГЛОБЯВАНЕТО;

СЪВЕТ ЗА ПОДДРЪЖКА

1. ПОЧИСТЕТЕ СТАРАТЕЛНО ОТ ПРАХ;
2. НАВЛАЖНЕТЕ МЕК ЧИСТ ПАРЦАЛ С ЛЕКО САПУНЕНА ВОДА.



НИКАКЪВ СЛУЧАЙ НЕ ПРЕНАТЯГАЙТЕ. СЛЕД ДЪЛГО ВРЕМЕ **СТЯГАМ** ОТНОВО **ВИНТОВЕТЕ**. ПАЗЕТЕ ИНСТРУКЦИИТЕ ЗА СГЛОБИАВАНЕ
АКО някоя част **ЛИПСВА** или е **счупена** **СВЪРЖЕТЕ** СЕ **МАГАЗИНА** ОТ КОИТО СТЕ ЗАКУПИЛИ МЕБЕЛИТЕ **МАКСИМАЛНО** ТЯЛО ПОДДЪРЖАНО ОТ ЧЕКМЕДЖЕТО Е **10KG**

НЕ ИЗПОЛЗВАЙТЕ АБРАЗИВНИ ПРОДУКТИ: ПРАХ, СТОМАНЕНА ВАТА, РАЗТВОРИТЕЛИ

ROMANIA

SFATURI DE MONTAJ

1. Studiați cu atenție instrucțiunile de asamblare;
2. Verificați dacă toate piesele care compun mobilierul sunt prezente;
3. Grupați și verificați hardware-ul;
4. Echipați-va cu sculele necesare asamblării;
5. Amenajează o zonă de asamblare;
6. Continuați cu asamblarea.

SFATURI DE ÎNTREȚINERE

1. Curățați praful bine;
2. Umeziți cu apă ușor săpun o cârpă moale și curată.



Nu forțați niciodată ansamblurile.
Strângeți șuruburile după o perioadă de utilizare.
Păstrați instrucțiunile de asamblare
Dacă o piesă lipsește sau este ruptă, contactați punctul de vânzare.
Greutatea maximă suportată de sertare este de 10 kg.

Nu utilizați niciodată praf abraziv, lână de sticlă sau solvenți.

SRPSKI

UPUTSTVO ZA MONTAŽU

1. PAŽLJIVO PROČITAJTE UPUTSTVO ZA MONTAŽU;
2. PREKONTROLIŠITE PREMA UPUTSTVU DA LI IMATE SVE POTREBNE DELOVE;
3. PREKONTROLIŠITE DA LI IMATE SVE ŠRAFOVE, MATICE I OSTALE METALNE DELOVE;
4. OSUGURAJTE POTREBAN ALAT ZA SASTAVLJANJE;
5. PRIPREMITE ODGOVARAJUĆI PROSTOR ZA MONTIRANJE;
6. UKOLIKO STE PROVERILI SVE GORE NAVEDENO MOŽETE ZAPOČETI MONTAŽU.

SAVETI ZA ODRŽAVANJE

1. UKLANJAJTE REDOVNO PRAŠINU I NEČISTOĆU;
2. ODRŽAVANJE MEKOM I VLAŽNOM KRPOM UZ UPOTREBU BLAGOG DETERDŽENTA.



PRILIKOM MONTIRANJA NE POKUŠAVATI NASILNO SPAJANJE DELOVA.
NAKON DUŽEG VREMENA KORIŠĆENJA PROIZVODA, ŠRAFOVE PONOVRNO PRIČVRSTITI.
UKOLIKO VAM NEDOSTAJE ODREĐENI DEO, MOLIMO VAS DA KONTAKTIRATE PRODAJNI CENTAR GDE STE NAMEŠTAJ KUPILI. FIOKA IMA Maksimalnu NOSIVOST 10 KG.

NE KORISTITI ABRAZIVNE KPRE, PUDERE, ČELIČNU VUNU ILI SREDSTVA KOJA MOGU OŠTETITI POVRŠINU NAMEŠTAJA.

(IT) ISTRUZIONI DI MONTAGGIO
(GB) ASSEMBLING INSTRUCTIONS
(FR) NOTICE DE MONTAGE
(SLO) NAVODILA ZA MONTAŽO
(SRB) UPUTSTVO ZA MONTAŽU

(D) MONTAGEANLEITUNG
(ES) INSTRUCCIONES DE MONTAJE
(P) INSTRUCOES DE MONTAGEM
(HR) UPUTE ZA MONTAZU
(RO) FOAIE CU INSTRUCIUNI
(BG) ИНСТРУКЦИИ ЗА СГЛОБЯВАНЕ

IMPORTANTE: Per evitare il ribaltamento accidentale del mobile è obbligatorio il fissaggio a muro. I tasselli necessari per il collegamento mobile/muro, dipendenti dal tipo di muro, non sono compresi. Consultare uno specialista in caso di dubbi.

IMPORTANT: To avoid the accidental tip-over of the furniture, the fixing of the furniture on the wall is mandatory. The needed hardware for the junction wall/furniture, depending of the nature of the wall, is not provided. If any doubt, consult a specialist.

IMPORTANT: Pour éviter le basculement accidentel du meuble, la fixation du meuble au mur est obligatoire. La visserie nécessaire pour la jonction mur/meuble, dépendante de la nature du mur n'est pas fournie. En cas de doute, consulter un spécialiste.

WICHTIG: Um die versehentliche Trübung der Möbel zu vermeiden, ist die Befestigung der Möbel an der Wand obligatorisch. Die benötigte Hardware für die Verbindungswand / Möbel, je nach Art der Wand, ist nicht vorgesehen. Wenn irgendwelche Zweifel, konsultieren Sie einen Spezialisten.

IMPORTANTE: Para evitar el vuelco accidental de los muebles, la fijación de los muebles en la pared es obligatoria. El hardware necesario para la pared / los muebles de la unión, dependiendo de la naturaleza de la pared, no se proporciona. En caso de duda, consulte a un especialista.

IMPORTANTE: Para evitar a queda accidental do mobiliário, a fixação dos móveis na parede é obrigatória. O hardware necessário para a junção parede / móveis, dependendo da natureza da parede, não é fornecido. Em caso de dúvida, consulte um especialista.

VAŽNO: Da bi se izbjeglo slučajno tip-over namještaja, fiksiranje namještaja na zidu je obavezno. Potreban hardver fot na spoj zida / namještaja, ovisno o prirodi zida, nije predviđeno. Ako imate bilo kakve sumnje, konzultirati stručnjaka.

VAŽNO: U CILJU IZBEGAVANJA SLUČAJNOG PREVRTANJA NAMEŠTAJA OBAVEZNO JE FIKSIRANJA ISTOG UZ ZID. NIJE PREDVIĐEN HARDVER FOT NA SPOJU ZIDA I NAMEŠTAJA. U SLUČAJU NEJASNOĆA POTREBNO JE KONSULTOVATI STRUČNO LICE.

OPOZORILO:

Da ne bi pohištva prevrnili, je pritrditev pohištva na steno obvezna.

Deli, potrebni za pritrditev pohištva na steno, ki so odvisni od vrste stene, niso priloženi.

Če ste v dvomih, se posvetujte s strokovnjakom.

ВАЖНО:

да избегнете Случайно преобръщане на МЕБЕЛИТЕ ТЕ ТРЯБВА Да бъдат фиксирани към стената Не са включени Дюбелите необходими За връзки мебели стени в зависимост от Вида на СТЕНАТА При съмнения се консултирайте със специалист

IMPORTANT: Pentru a evita rasturnarea accidentala a mobilierului, fixarea pe perete este obligatorie. Mufele necesare pentru racordarea dulap/perete, in functie de tipul de perete, nu sunt incluse. Consultați un specialist dacă aveți dubii.

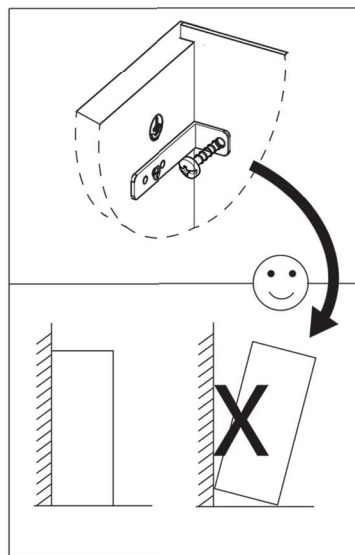

ARES

(IT) ISTRUZIONI DI MONTAGGIO
(GB) ASSEMBLING INSTRUCTIONS
(FR) NOTICE DE MONTAGE
(SLO) NAVODILA ZA MONTAŽO

(D) MONTAGEANLEITUNG
(ES) INSTRUCCIONES DE MONTAJE
(P) INSTRUCOES DE MONTAGEM
(HR) UPUTE ZA MONTAZU

	Cod.	Parcel number	Size - mm.	Description	n.
1	8WEVEFF004D	8WEVEFF004D		FRIDGE	1
2	8WEPAKEX6004	8WEPAKEX6004		HOOD	1
3	8WEVEPC005N	8WEVEPC005N		HOB	1
4	8WXXLXO791D	8WXXLXO791D		SINK	1
5	8WEVEFO003N	8WEVEFO003N		OVEN	1
6	8WEVELV001	8WEVELV001		DISH WASHER	1

	Cod.	Parcel number	Size - mm.	Fridge column	n.
8-1	4WKTBI3CA004	2WMMBI6035	563X531X18	TOP	1
8-2	4WKTBI1BA004	2WMMBI6035	563X531X18	BOTTOM	1
8-3	PWXXBI3FD501	2WKTBI6741	2040X560X18	RH SIDE	1
8-4	PWXXBI3FS501	2WKTBI6741	2040X560X18	LH SIDE	1
8-5	V54WXXBI7SP804	2WGABI6050L	596X1315X18	DOOR	1
8-6	V54WASBI7SP604	2WGABI6050L	596X715X18	DOOR	1
	9WXXAPFA601	9WXXAPFA601		UNDER FRIDGE PROTECTOR	1
8-7	5MRBA2013	2WKTBI6741	333X578X3	BACK	1
8-8	5MRBA2025	2WKTBI6741	210X150X3	BACK	1

	Cod.	Parcel number	Size - mm.		n.
9	4WMMCMTBL1874	2WMMCMTBL1874	1872X600X38	TOP	1
10	4WMMCMTBL1764	2WMMCMTBL1764	1702X600X38	TOP	1

11	V54WXXBI1FI241	2WXXBLFB850	840X580X18	FINISHING SIDE	1
----	----------------	-------------	------------	----------------	---

	Cod.	Parcel number	Size - mm.		n.
12	2WGDBIPP607BLS	2WGDBIPP607BLS		WALL UNIT L.60 H.72	1
13	2WMMBIPV607TBL	2WMMBIPV607TBL		WALL UNIT L.60 H.72	1
14	2WGDBIPP457BLS	2WGDBIPP457BLS		WALL UNIT L.45 H.72	1

15	V54WASBI7SP604	2WASBI7129L	596X715X18	DOORS	2
----	----------------	-------------	------------	-------	---

16	V54WXXB4FCA201	2WMMBIFCA004L	648X716X18	LH SIDE	1
17	V54WXXBI7SP603	2WMMBIFCA004L	446X715X18	DOOR	1
18	V54WXXBI4FA201	2WMMBIFCA004L	70X717X18	FRONT JOINT CHAIN	1
19	4WXXBI4FA202	2WMMBIFCA004L	70X715X18	BACK JOINT CHAIN	2

	Cod.	Parcel number	Size - mm.	Sink cabinet L.60	n.
20	9WXXNC1FA132	2WMMBI6102	563X67X18	JOINT CHAIN	3
21	4WKTBI1BA004	2WMMBI6102	563X531X18	BOTTOM	1
22	4WXXBI1FI201	2WMMBI6102	720X560X18	RH LH SIDE	2

	Cod.	Parcel number	Size - mm.	Cabinet L.60	n.
23	9WXXNC1FA132	2WMMBI6005	563X67X18	JOINT CHAIN	2
24	4WKTBI1BA004	2WMMBI6005	563X531X18	BOTTOM	1
25	4WXXBI1FI201	2WMMBI6005	720X560X18	RH LH SIDE	2
26	4WXXBI1RI004	2WMMBI6005	562X491X18	SHELF	1
27	5MRBA2010	2WMMBI6005	708X578X3	BACK	1

	Cod.	Parcel number	Size - mm.	Cabinet L.90	n.
28	9WXXNC1FA130	2WMMBI6007	863X67X18	JOINT CHAIN	2
29	4WKTBI1BA006	2WMMBI6007	863X531X18	BOTTOM	1
30	4WXXBI1FI201	2WMMBI6007	720X560X18	RH LH SIDE	2
31	4WXXBI1RI006	2WMMBI6007	862X491X18	SHELF	1
32	5MRBA2053	2WMMBI6007	708X878X3	BACK	1

	Cod.	Parcel number	Size - mm.		n.
33	2WMMBIBCC607BL	2WMMBIBCC607BL		3 DRAWERS CHEST	1
34	2WMMZA013	2WMMZA013		PLINT	1
35	V54WASBI7SP614	2WAUBLJSL406	596X715X18	DISH WASHER DOOR	1
36	2WGDBICF250BLD	2WGDBICF250BLD		OVEN COLUMN	1
37	2WMMZA013	2WMMZA013		BACKSPLASH	1

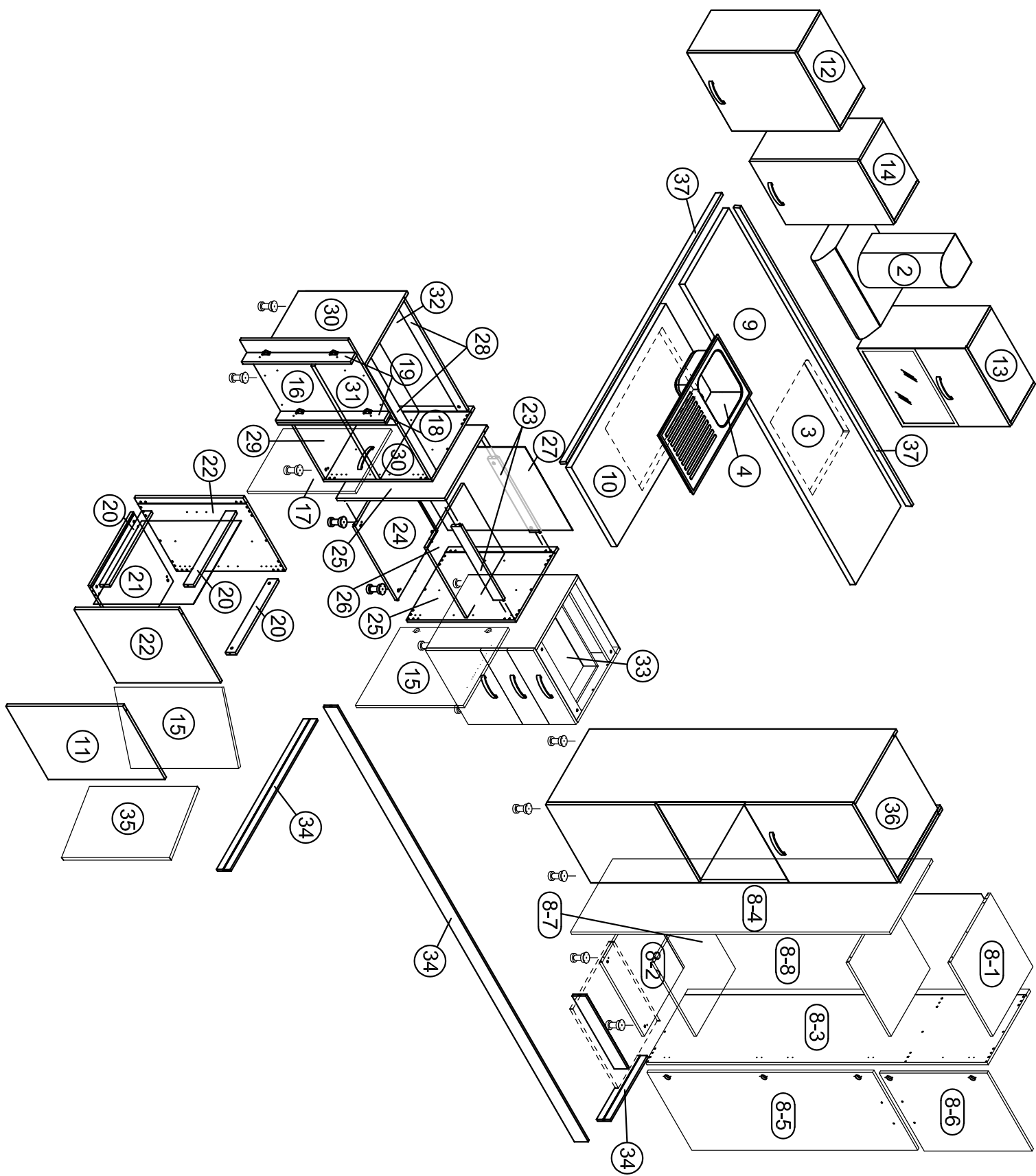

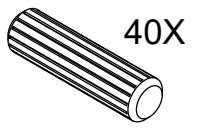

5SIFA2000



FFMON2018

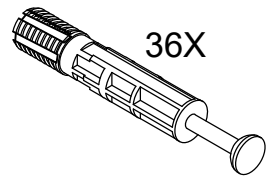

FFMON2051

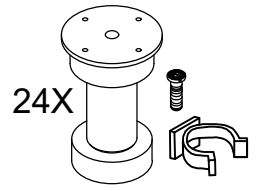

8WXXAPBN01



FFCOL2000

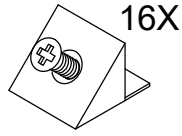

FFFSZ2007



FFVAN2056
3.5X15

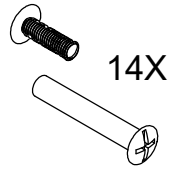

FFGPN2226

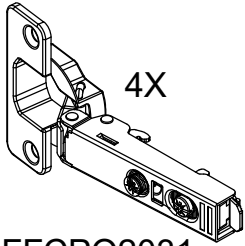

FFCPO2031

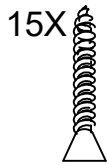

FFVAN2234
4x18

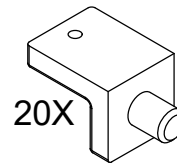

FFPC2004

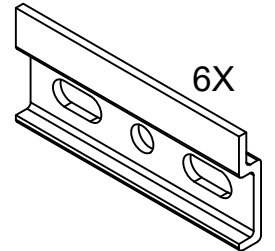

FFBAR5007

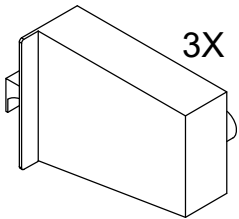

Z-ATTA01

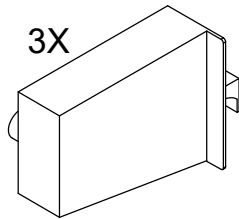

Z-ATTA02

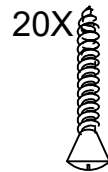

FFVAN2050
4x25

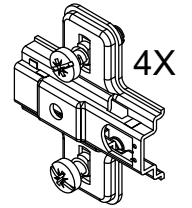

FFBMP2020



FFPAR1050

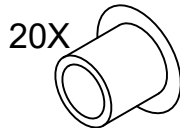

FFTCB2000

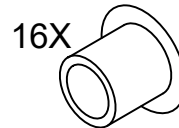

FFTCGC2001



FFTADBI1003

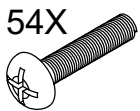

FFVAN2018
4MAX22

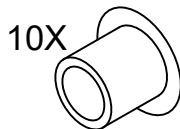

FFTCB2001



FFTCB2005

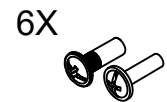

FFGPN2233



FFMAN2081

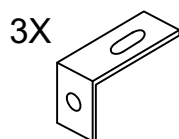

FFPFZ2079

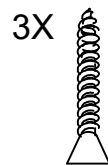

FFVAN2247
5x50

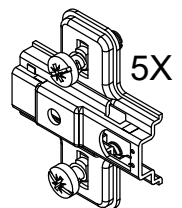

FFBMP2007

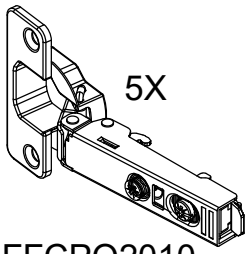

FFCPO2010

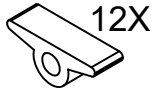

FFRPN2014

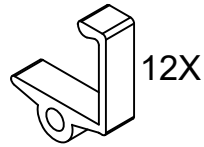

FFRPN2015

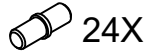

FFRPN2016



FFVAN2252
4X30

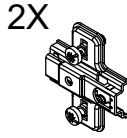

FFBMP2010

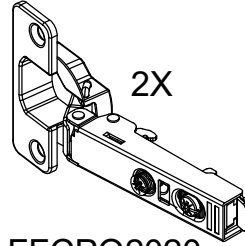

FFCPO2020



FFFSZ2034



FFVAN2239
4MAX15



FFVAN2224
4X20



FFVAN2248
4X60

12 INR



5SIFA2000

10 INR



FFMON2065

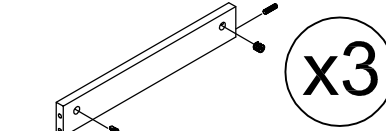
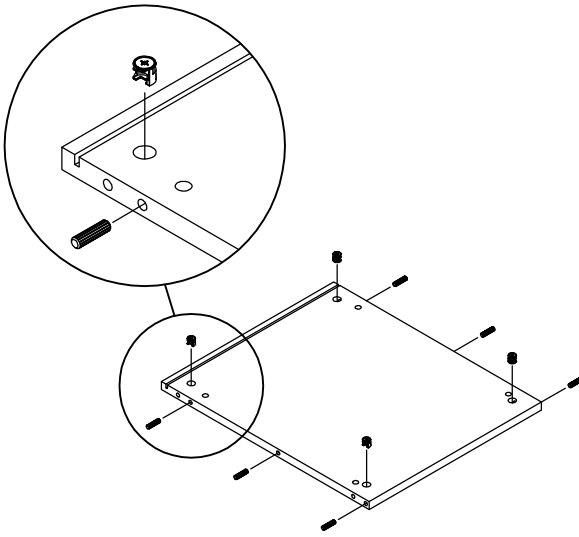

8 INR

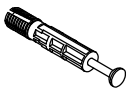

FFMON2051

2 INR

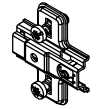

FFBMP2020

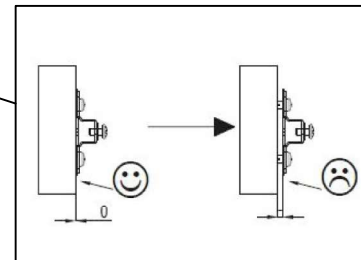
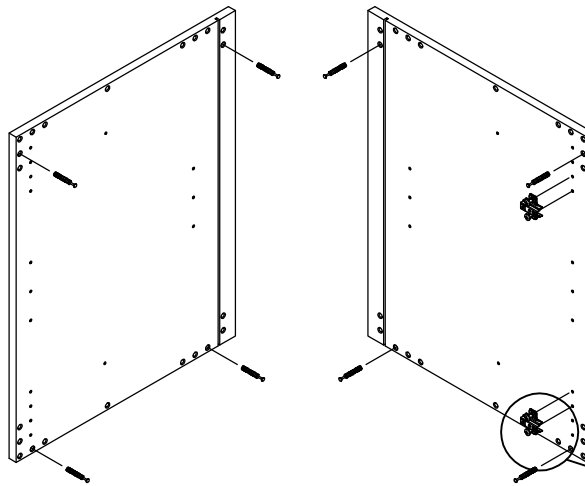

4 INR



8WXXAPBN01

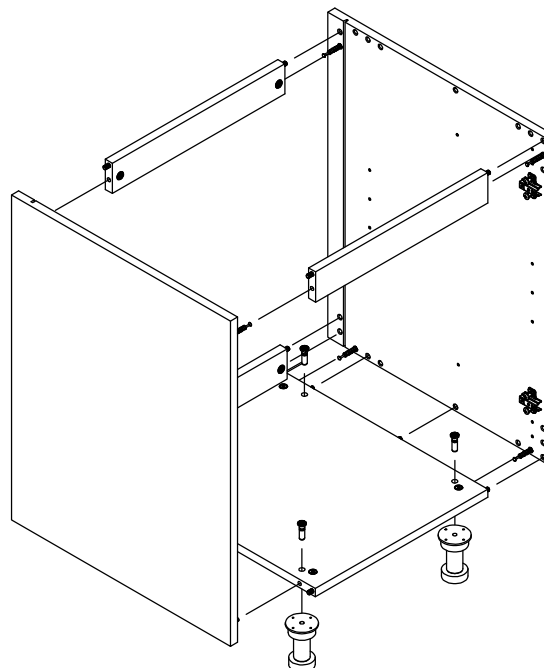

- 4 INR
FFVAN2056
3.5X15
- 2 INR
FFVAN2018
4MAX22
- 2 INR
FFCPO2031
- 1 INR
FFMAN2270NE

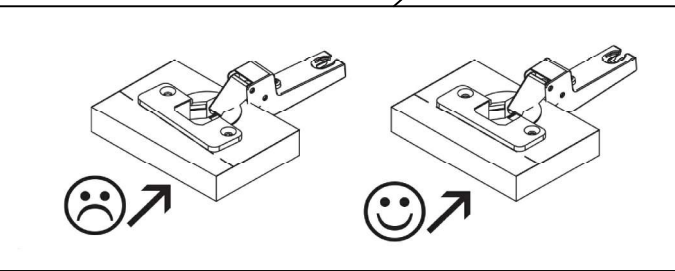
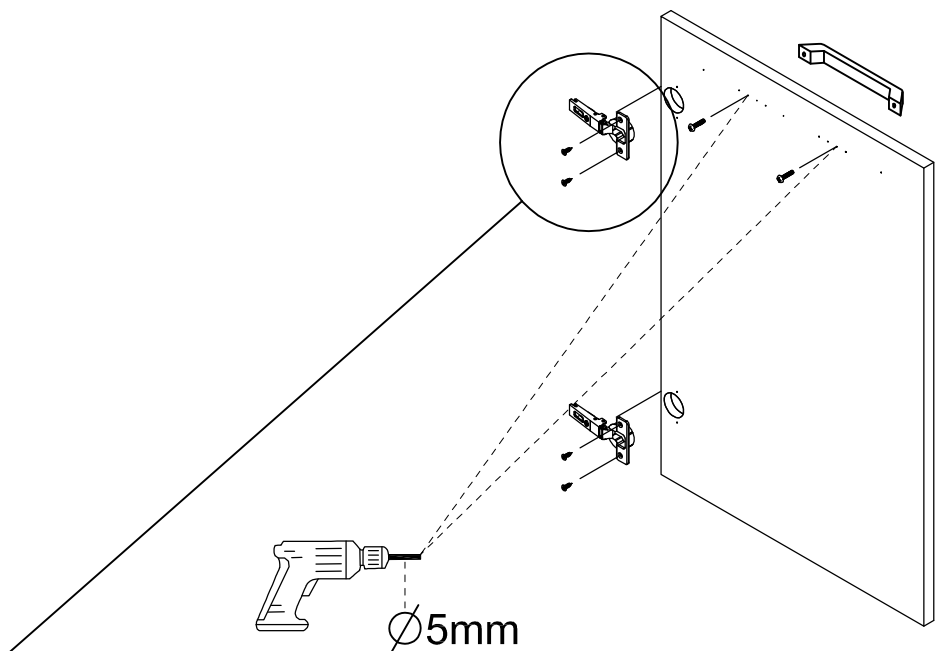

- 2 INR
FFPAR1050
 - 1 INR
9WXXAPLA451
-

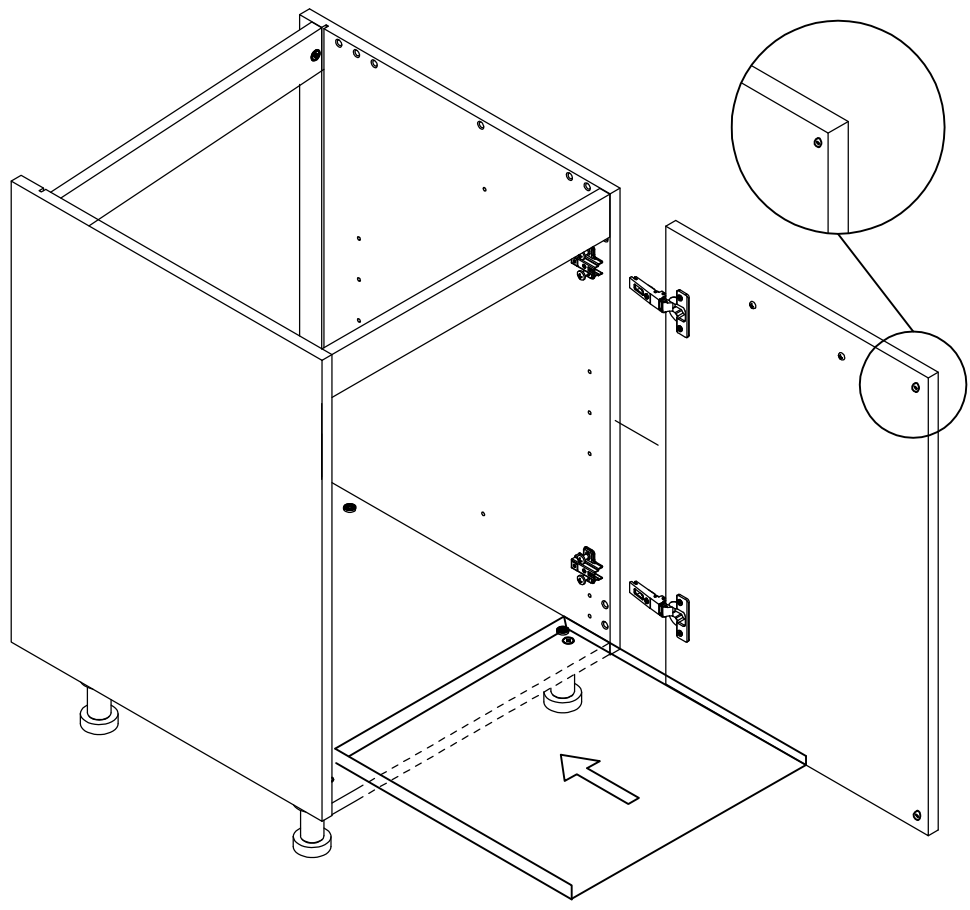

10 NR



5SIFA2000

8 NR



FFMON2065

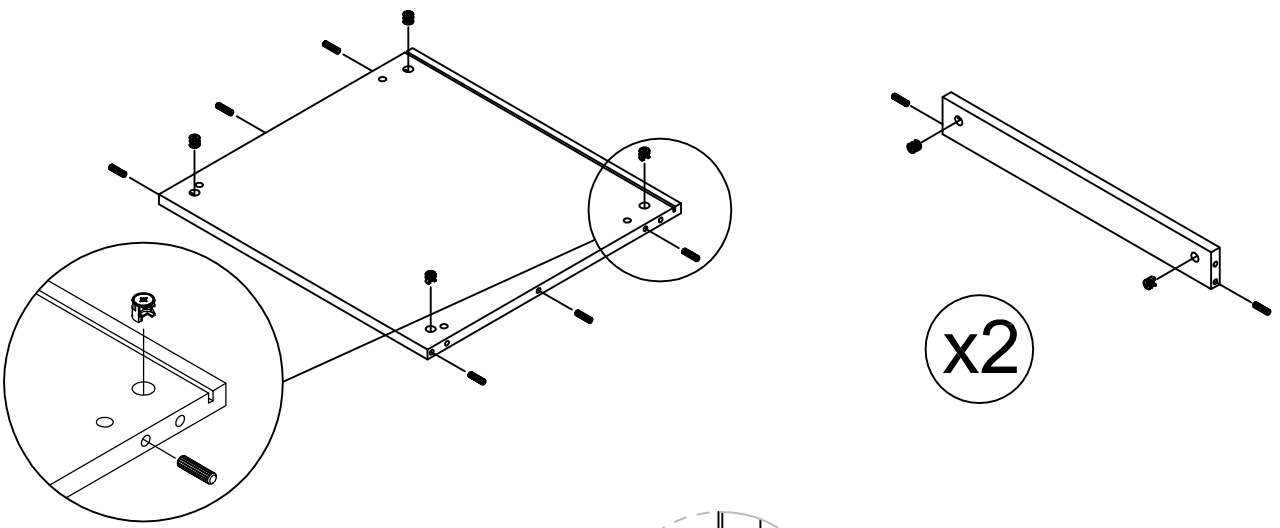

8 NR

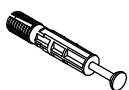

FFMON2051

2 NR

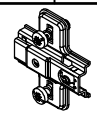

FFBMP2020

2 NR



FFRPN2014

2 NR



FFRPN2015

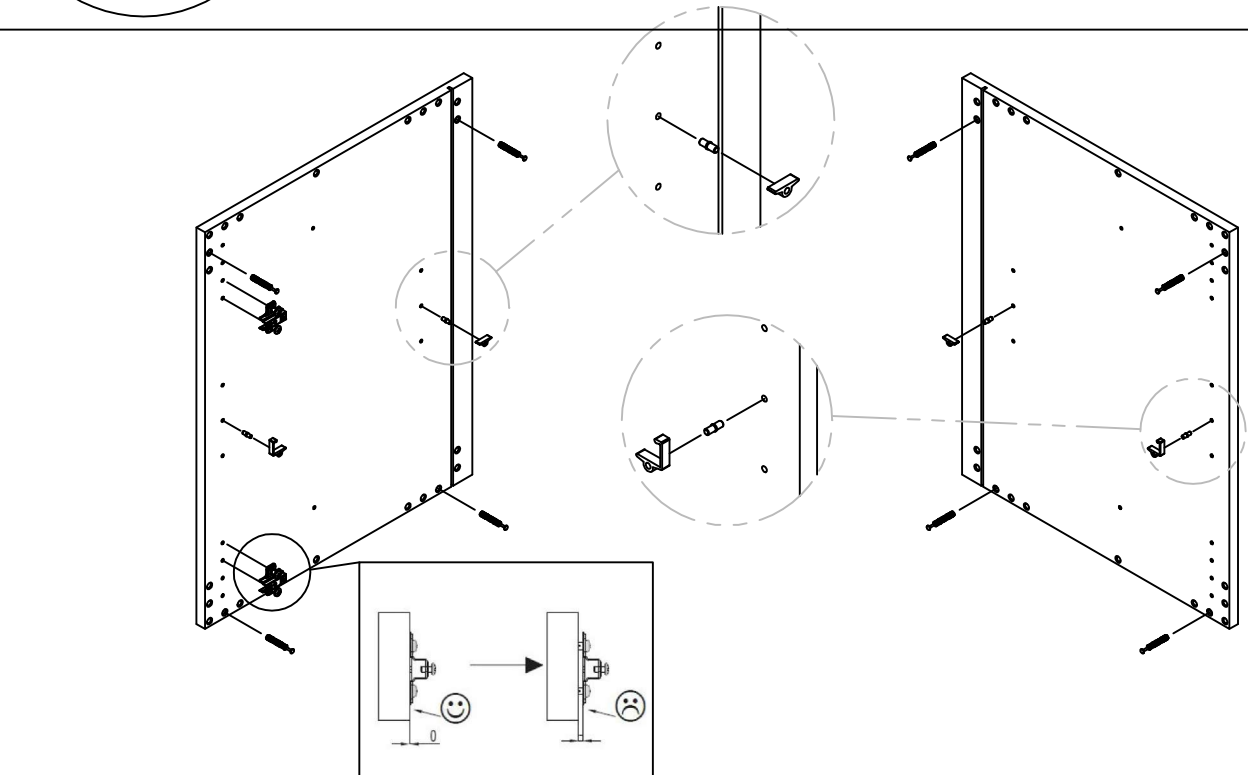

4 NR



FFRPN2016

4 NR

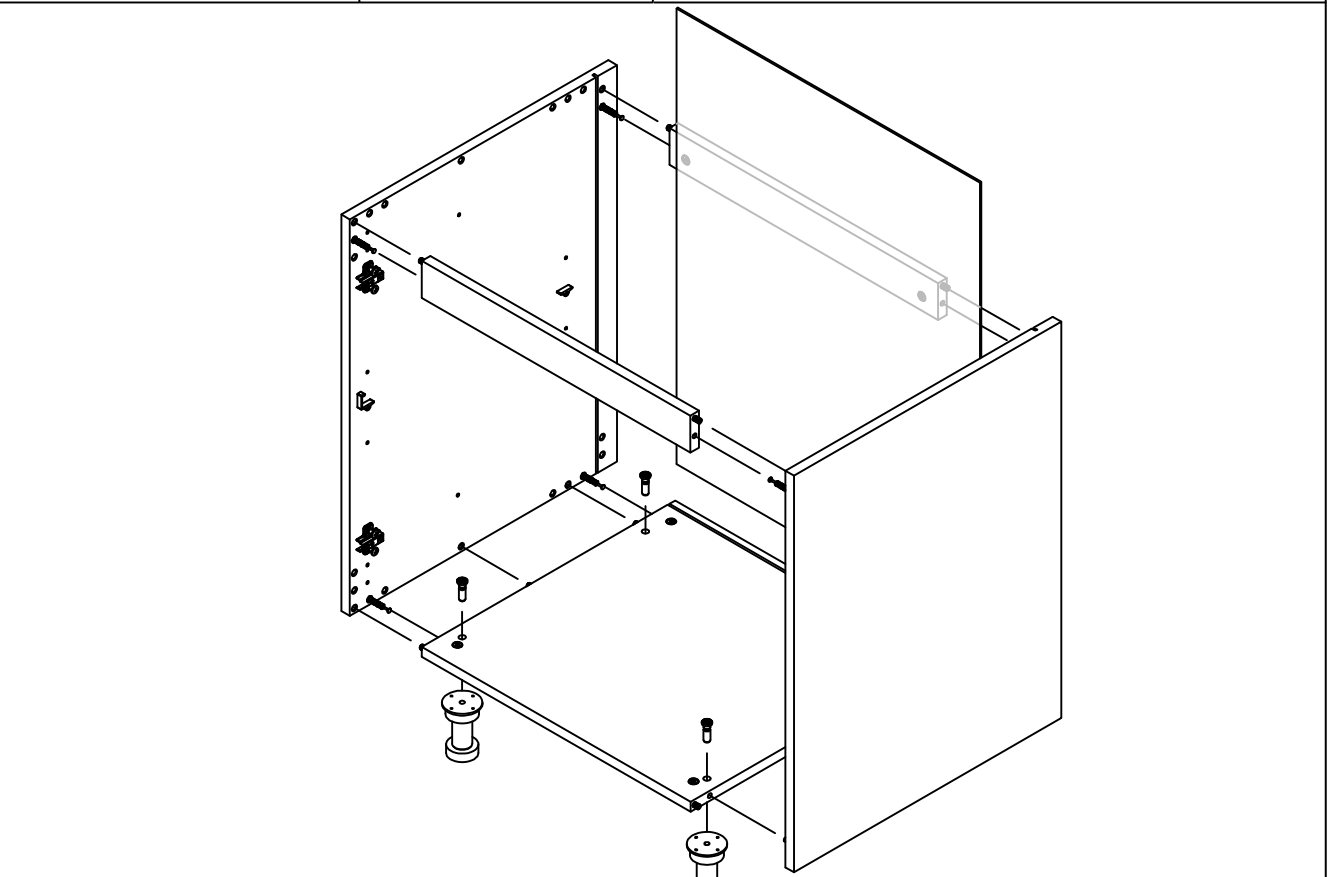

8WXXAPBN01

16 ^{NR}



FFFSZ2007

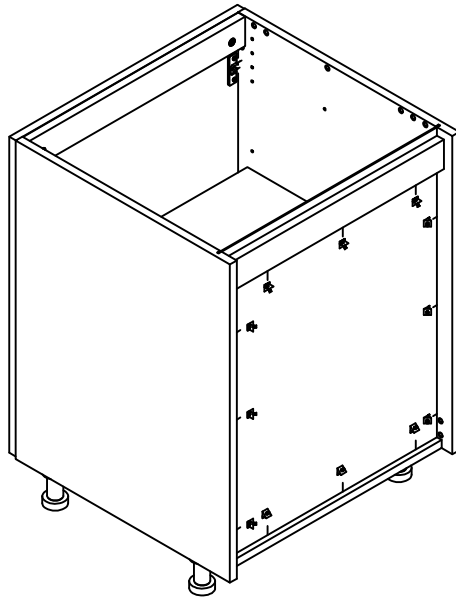

4 ^{NR}



FFVAN2056
3.5X15

2 ^{NR}



FFVAN2018
4MAX22

2 ^{NR}

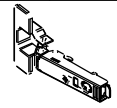

FFCPO2031

1 ^{NR}

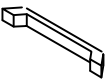

FFMAN2270NE

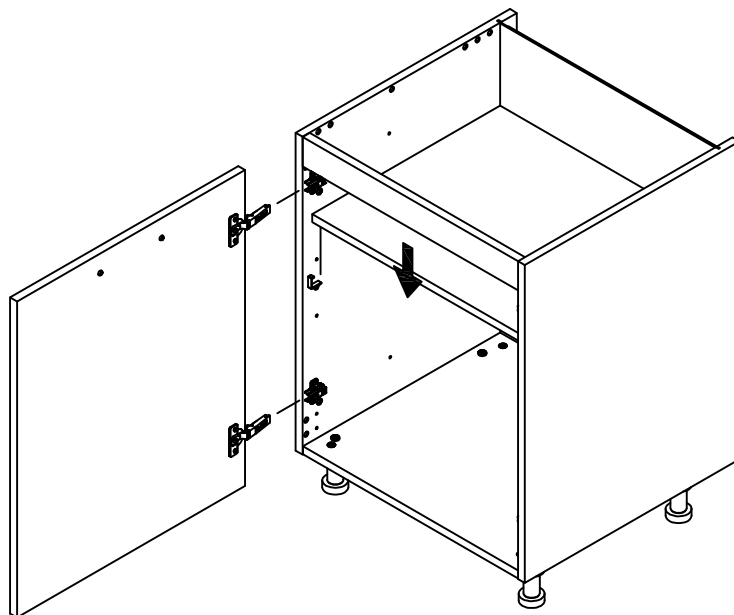
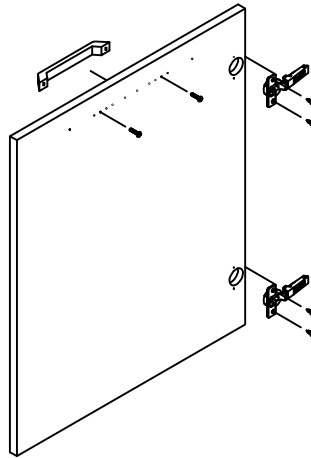
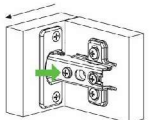
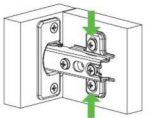
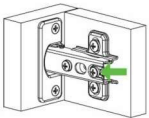

4 INR



FFMON2065

6 INR

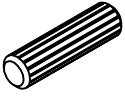

5SIFA2000

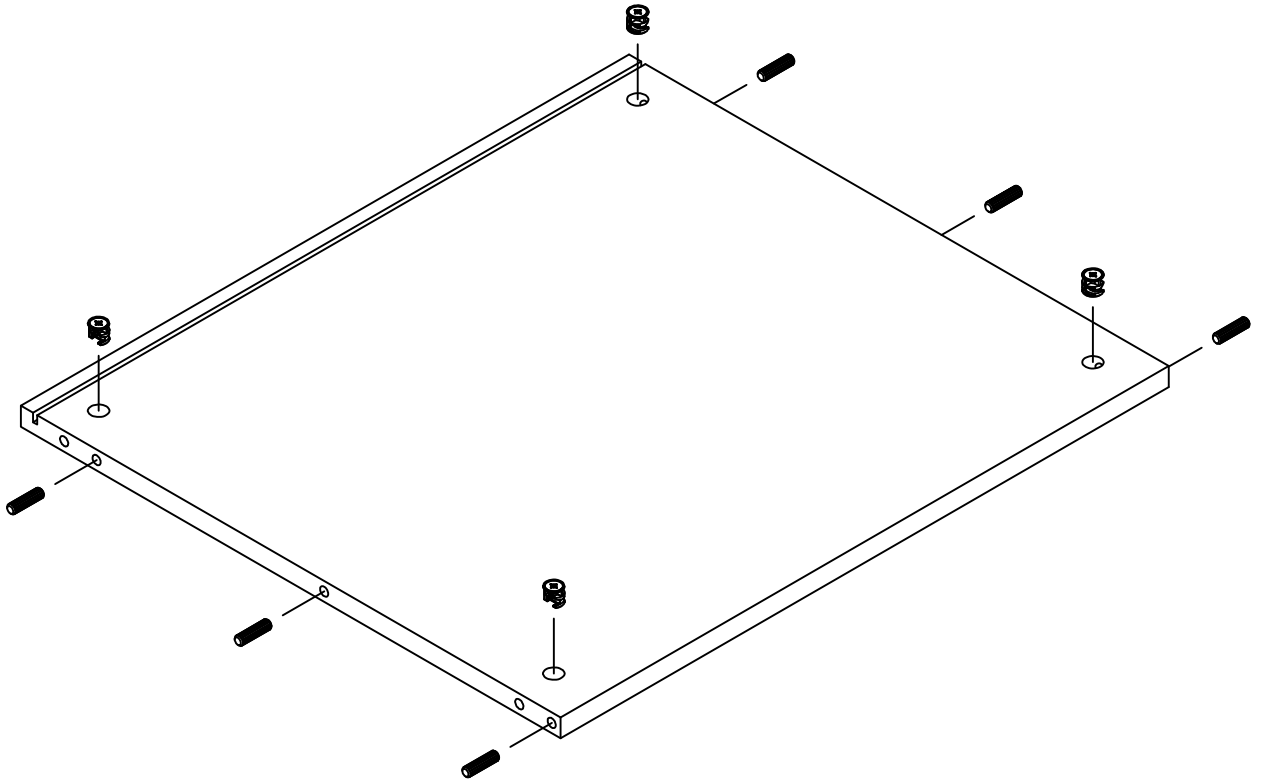

4 INR



FFMON2065

6 INR

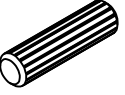

5SIFA2000

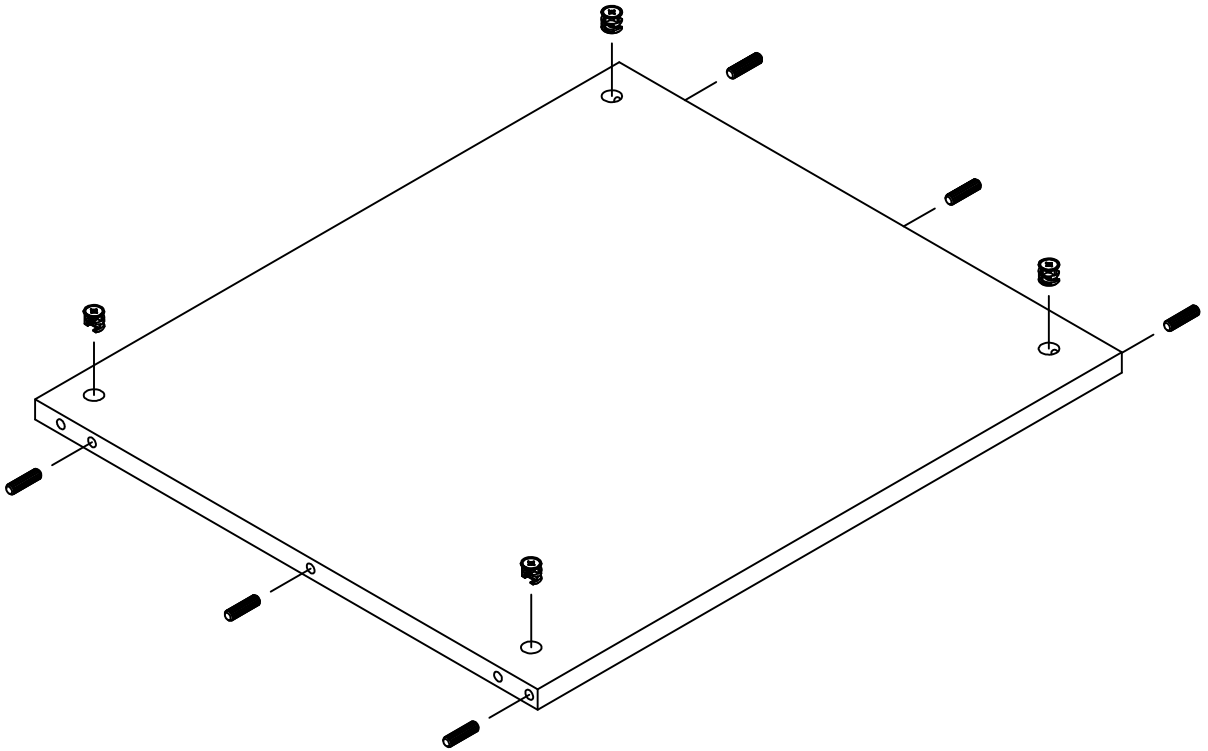

4 INR



FFMON2065

6 INR

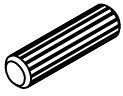

5SIFA2000

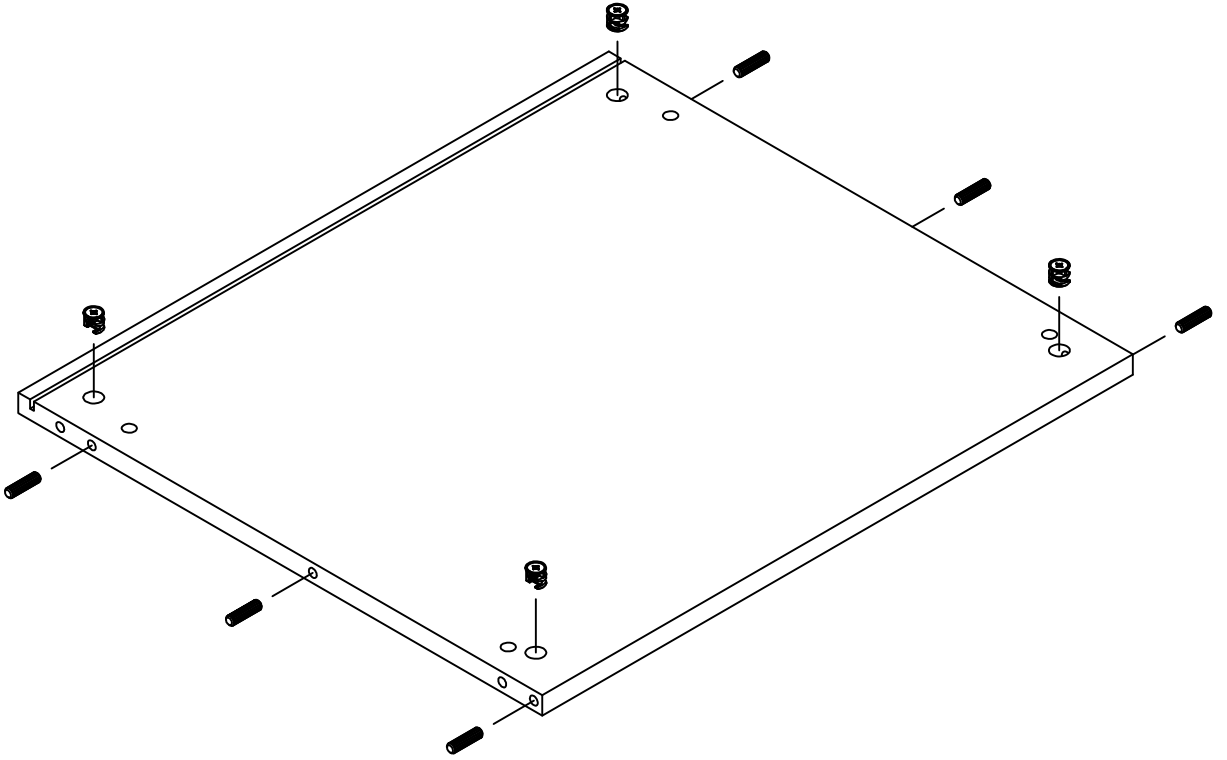

16 INR



FFMON2083

5 INR

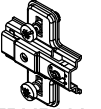

FFBMP2007

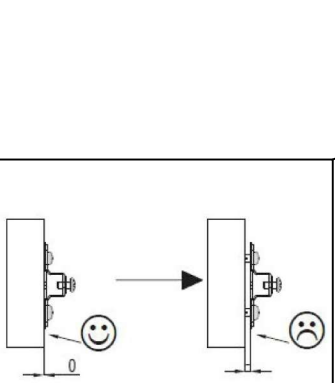
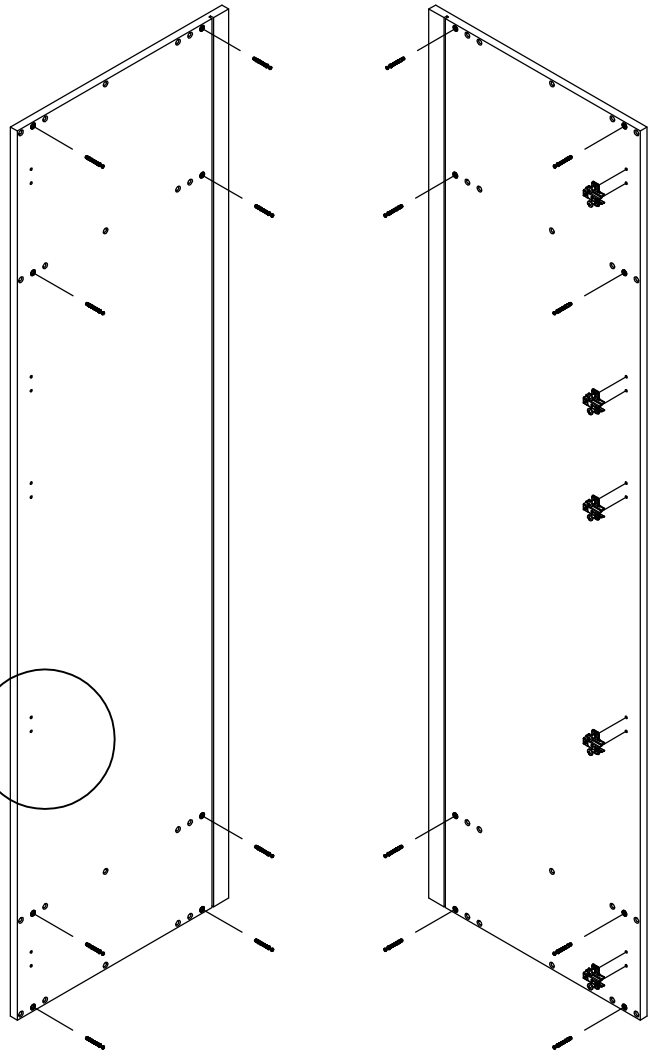

4 INR

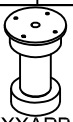

8WXXAPBN01

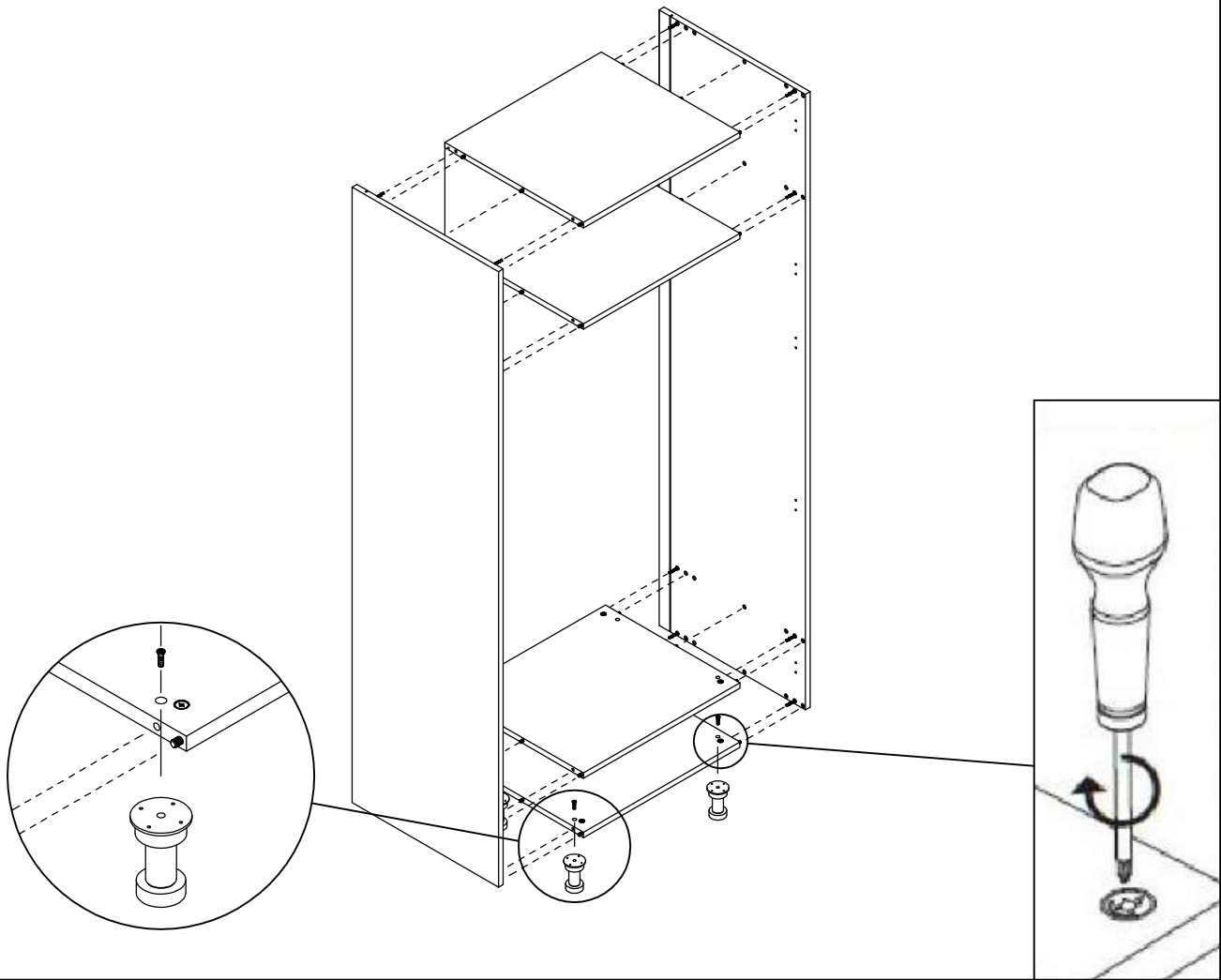

6 INR



FFFSZ2007

2 INR



8SPFE4146

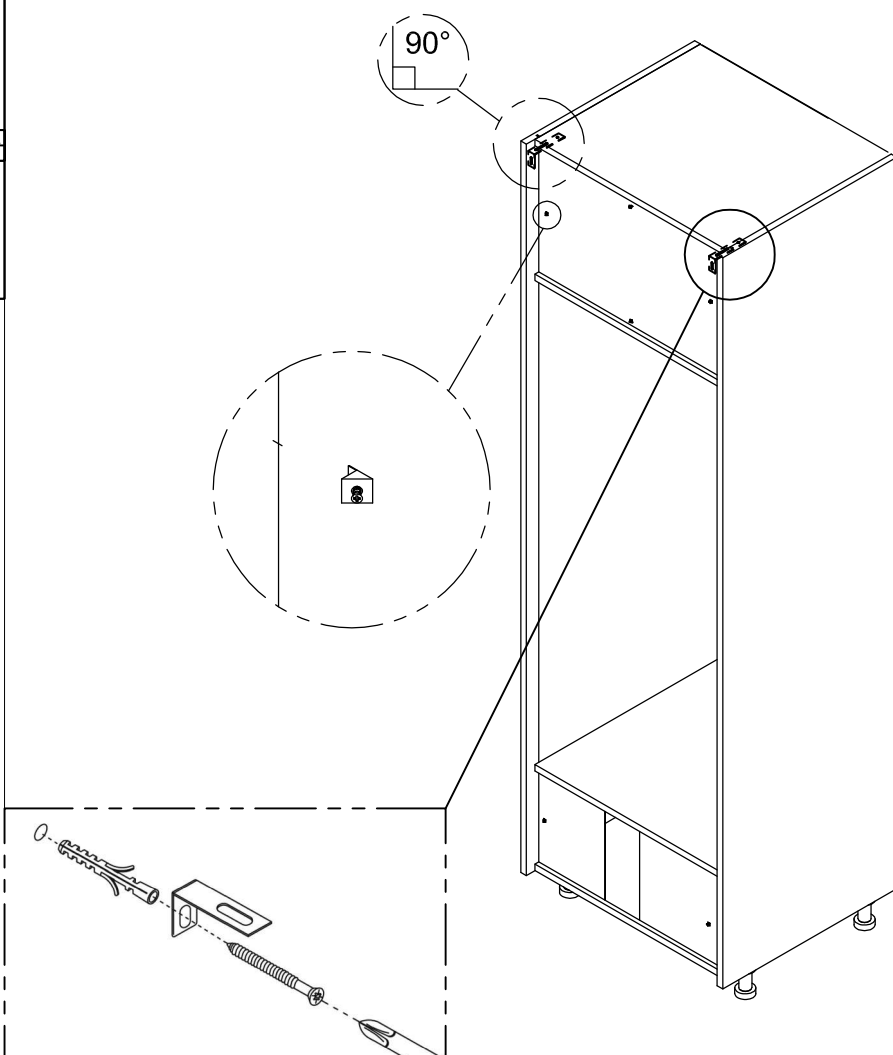

- 5 INR
FFCPO2010
- 10 INR
FFVAN2056
3,5x15
- 2 INR
8X
FFMAN2270NE

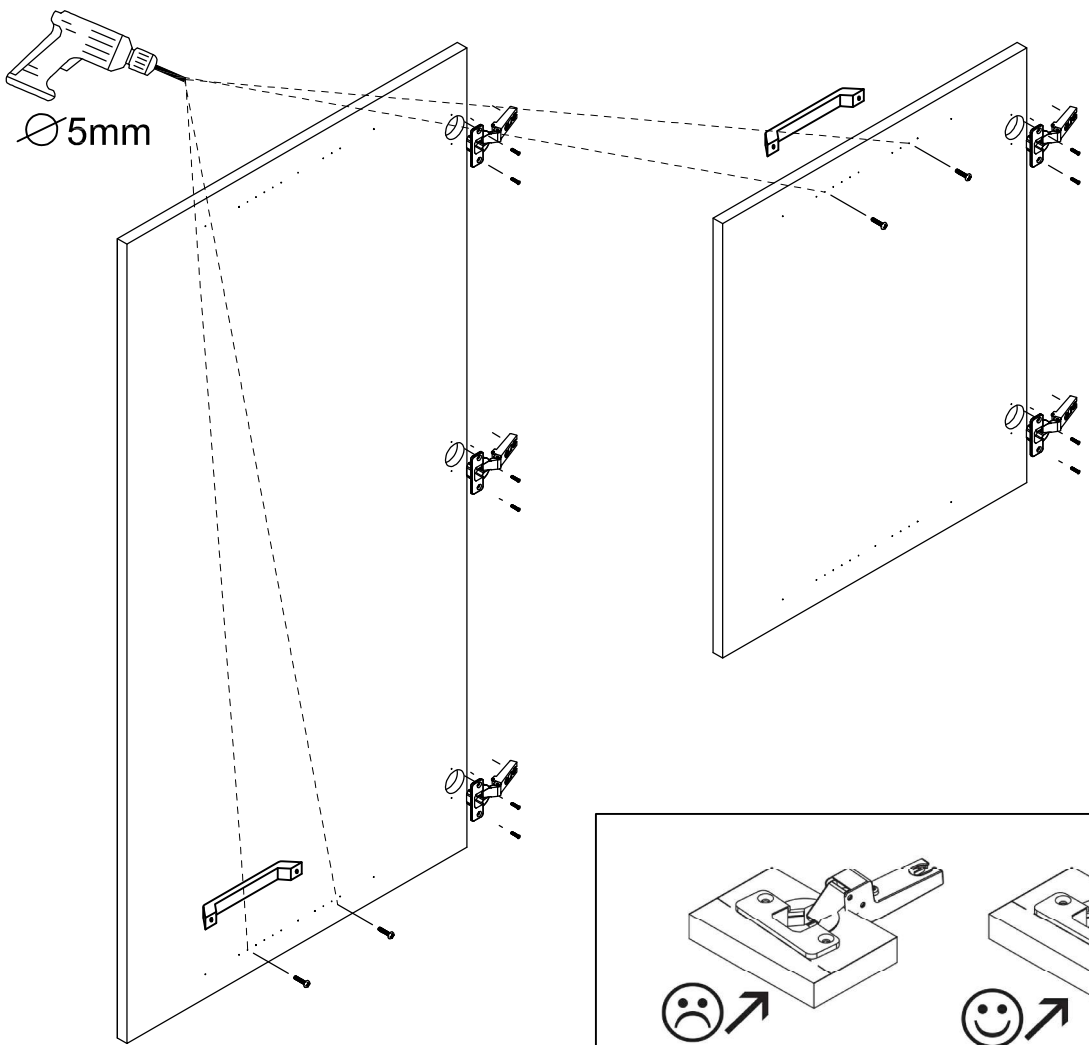

- 4 INR
FFPAR1050
- 1 INR
9WXXAPFA601

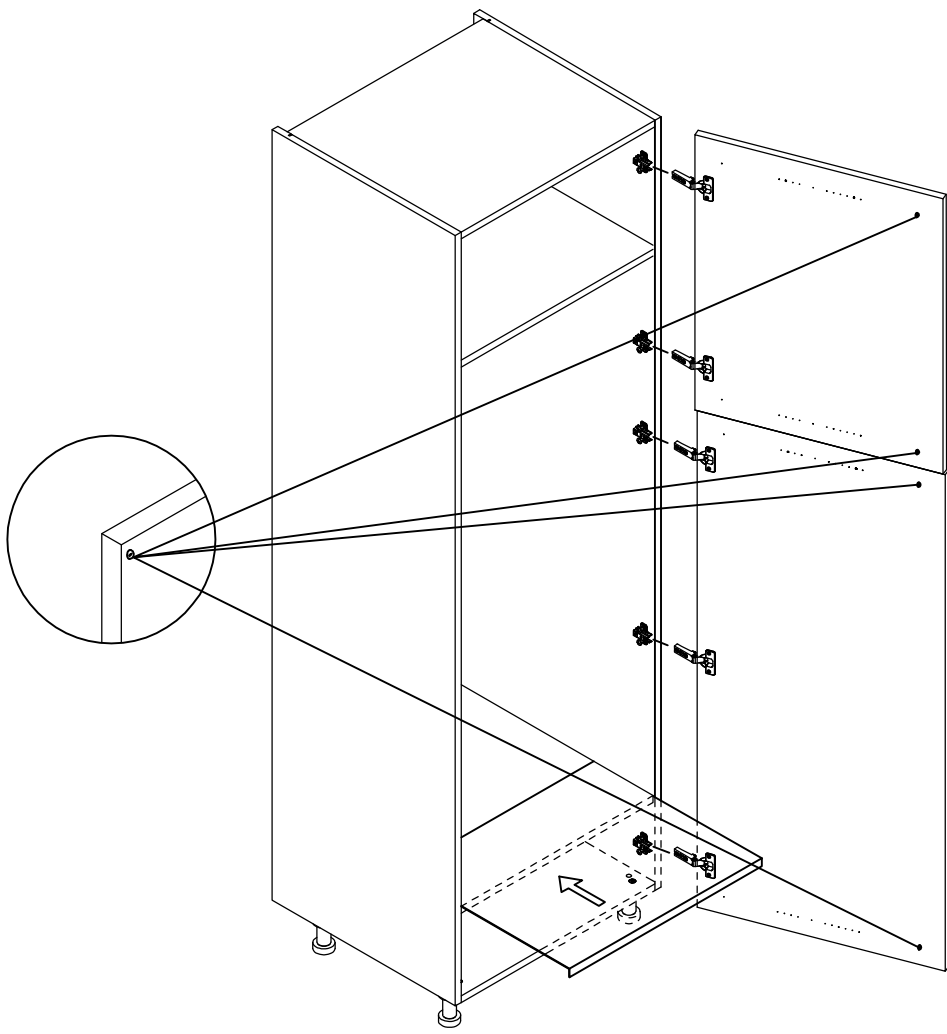

10 INR

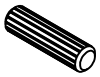

5SIFA2000

8 INR



FFMON2065

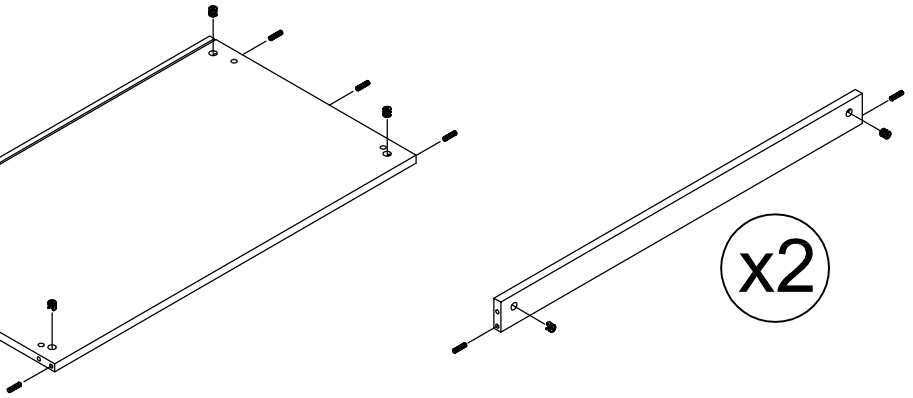
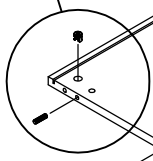
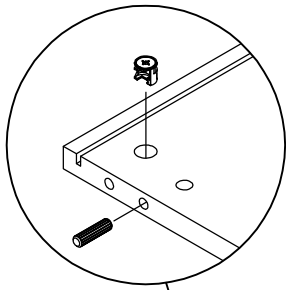

8 INR

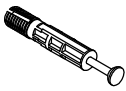

2 INR



FFRPN2014

2 INR

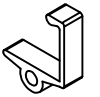

FFRPN2015

4 INR



FFRPN2016

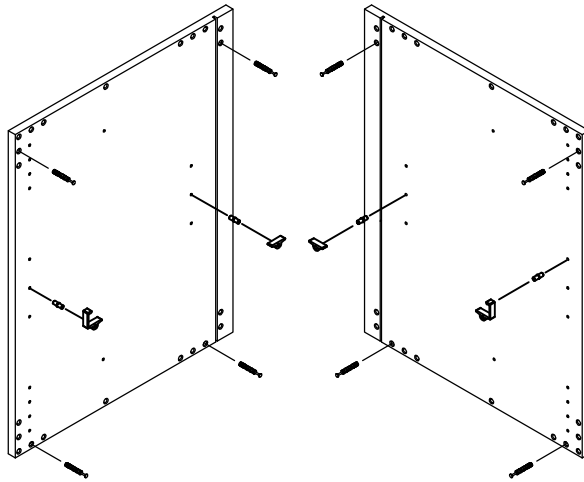

4 INR



8WXXAPBN01

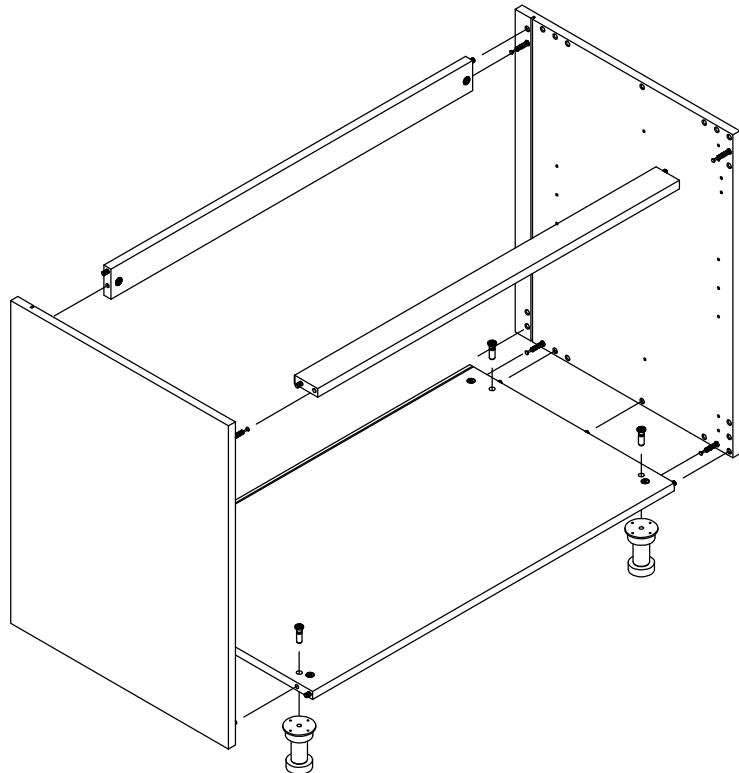
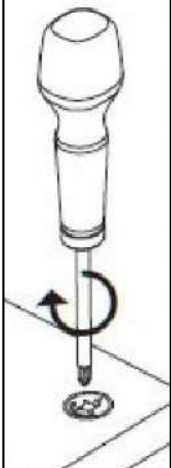

6 ^{NR}



FFGPN2233

6 ^{NR}



FFVAN2248

2 ^{NR}

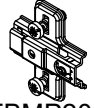

FFBMP2010

10 ^{NR}



FFFSZ2034

4 ^{NR}



FFVAN2239

2 ^{NR}



FFVAN2252

8 ^{NR}



FFVAN2224

12 ^{NR}



FFVAN2224

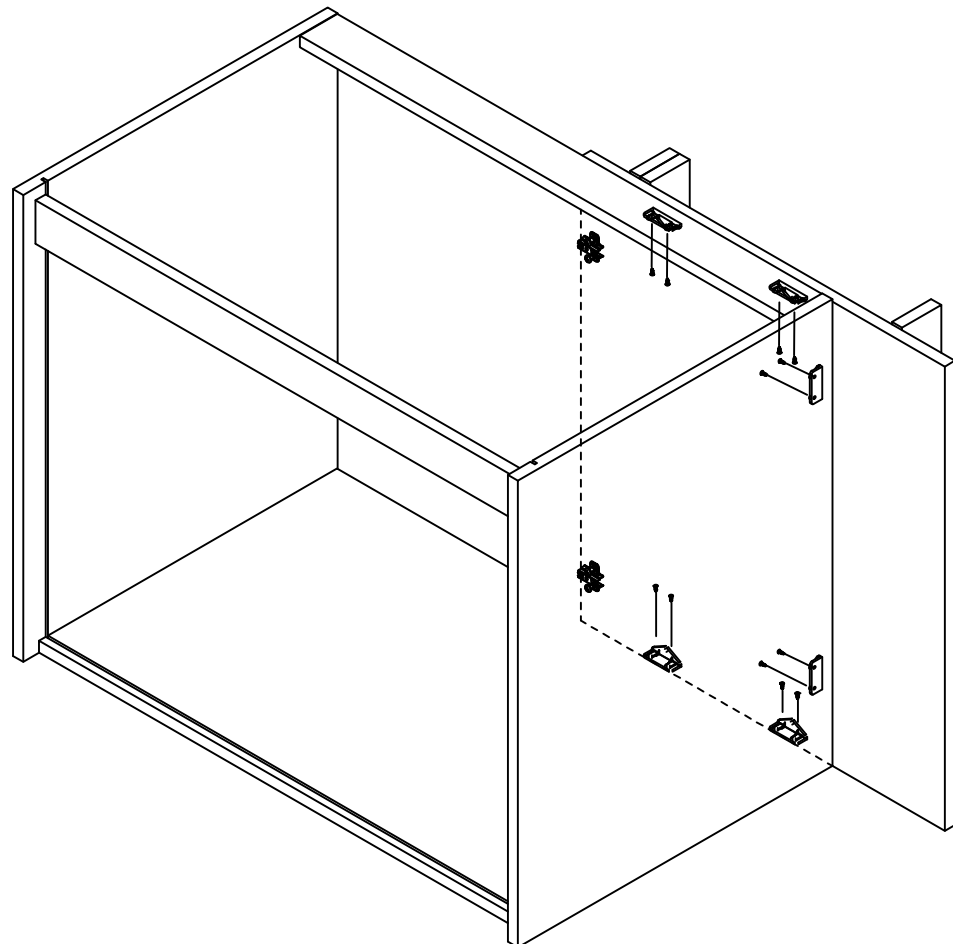
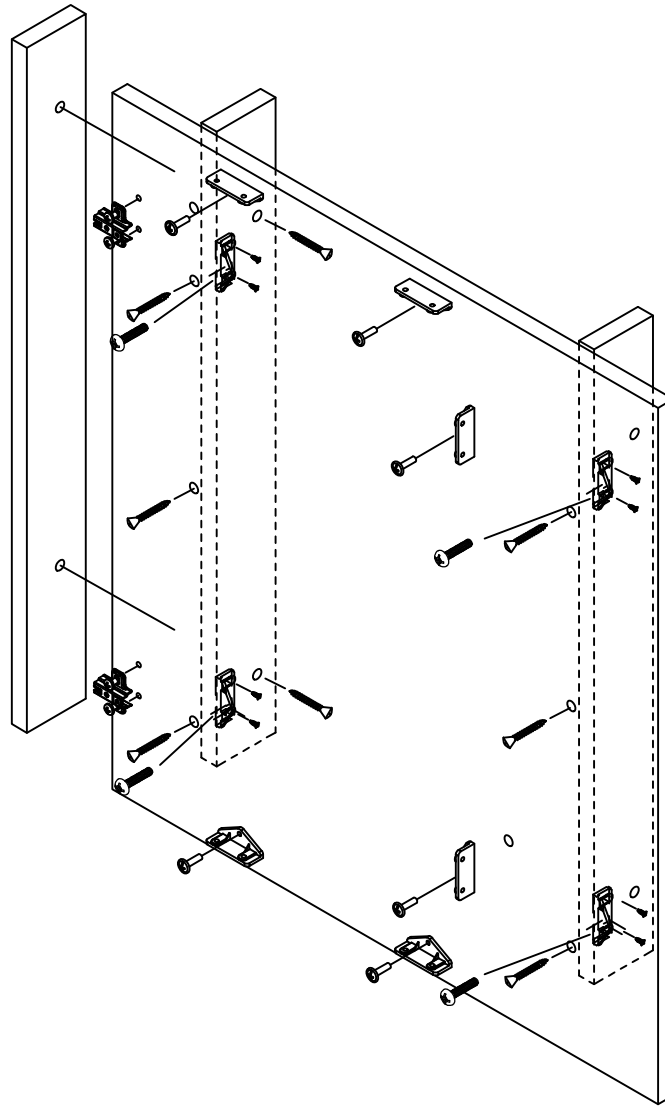

4 INR



FFVAN2056

2 INR



FFVAN2018

2 INR

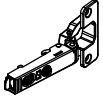

FFCPO2020

1 INR



FFMAN2081

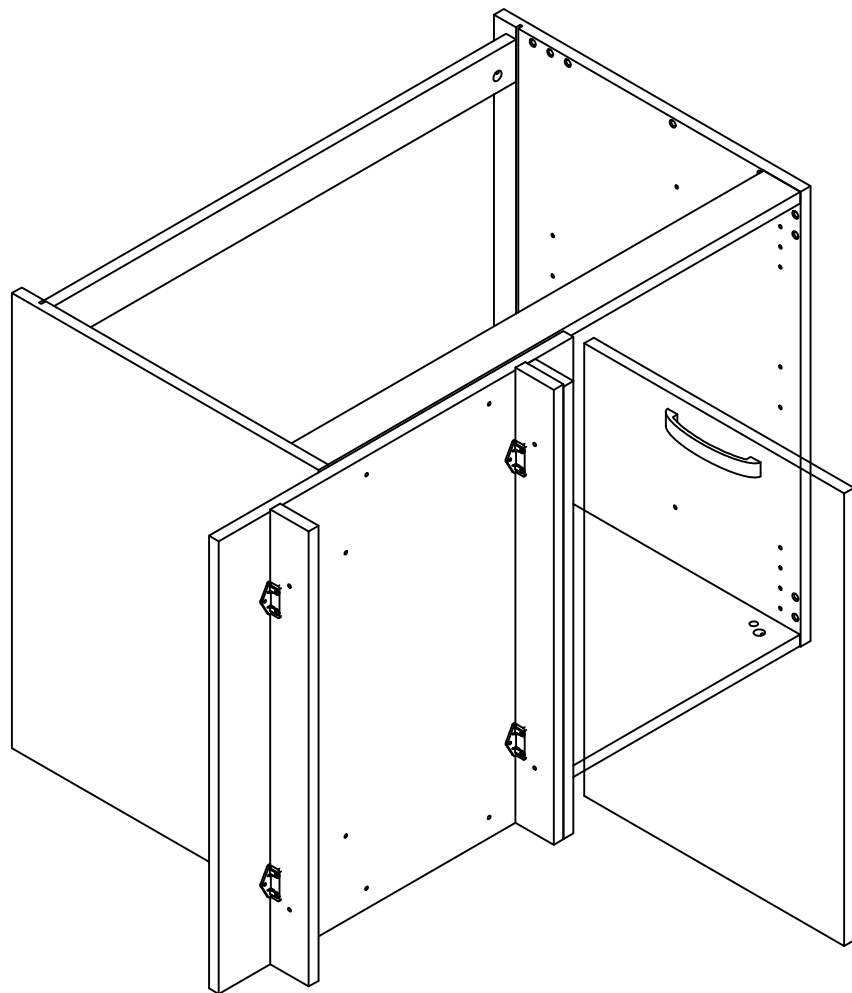
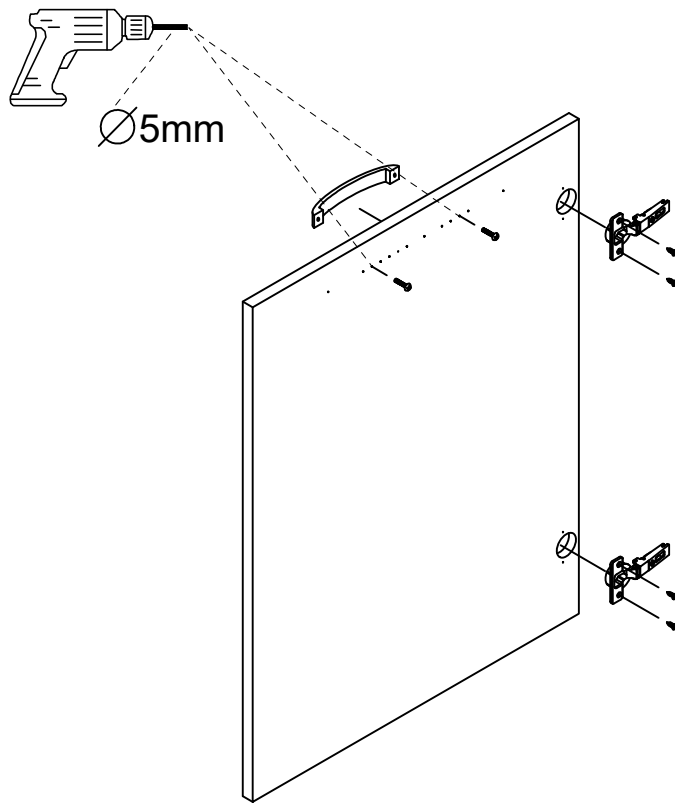

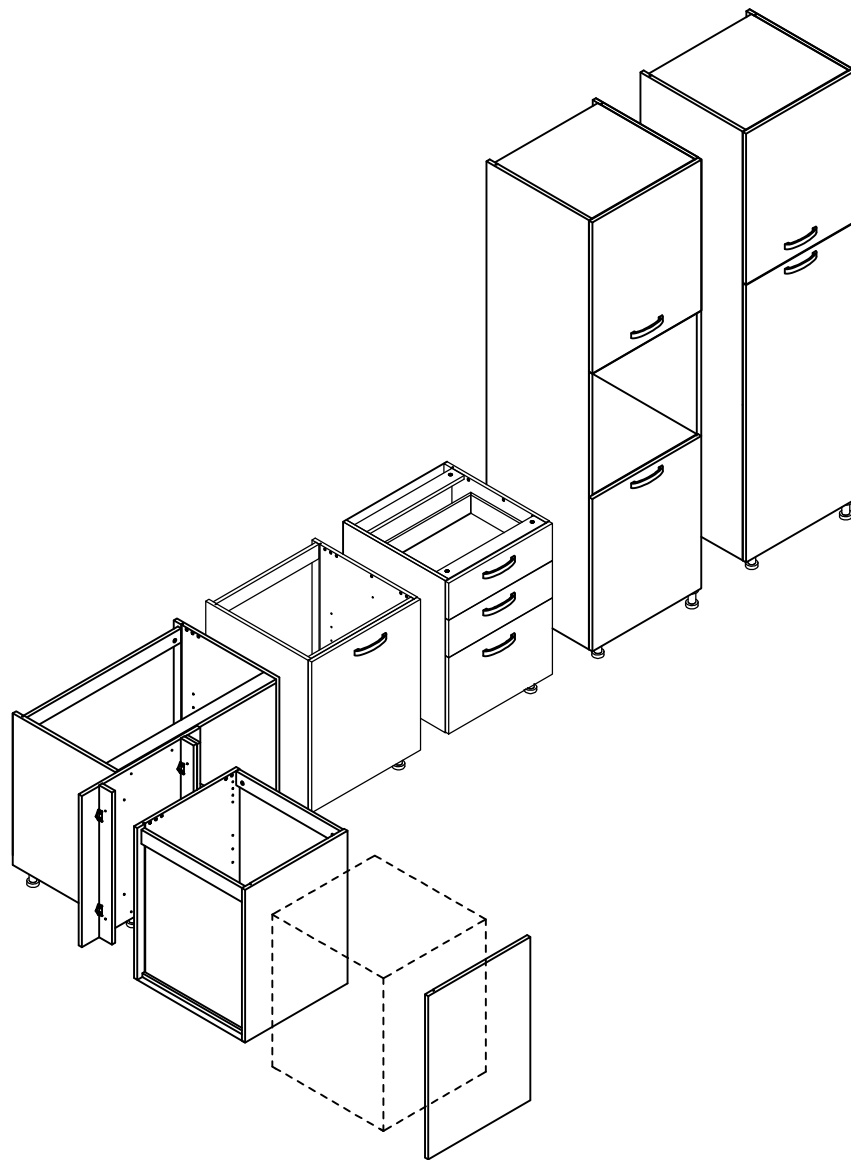

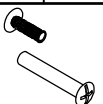

X 4 INR

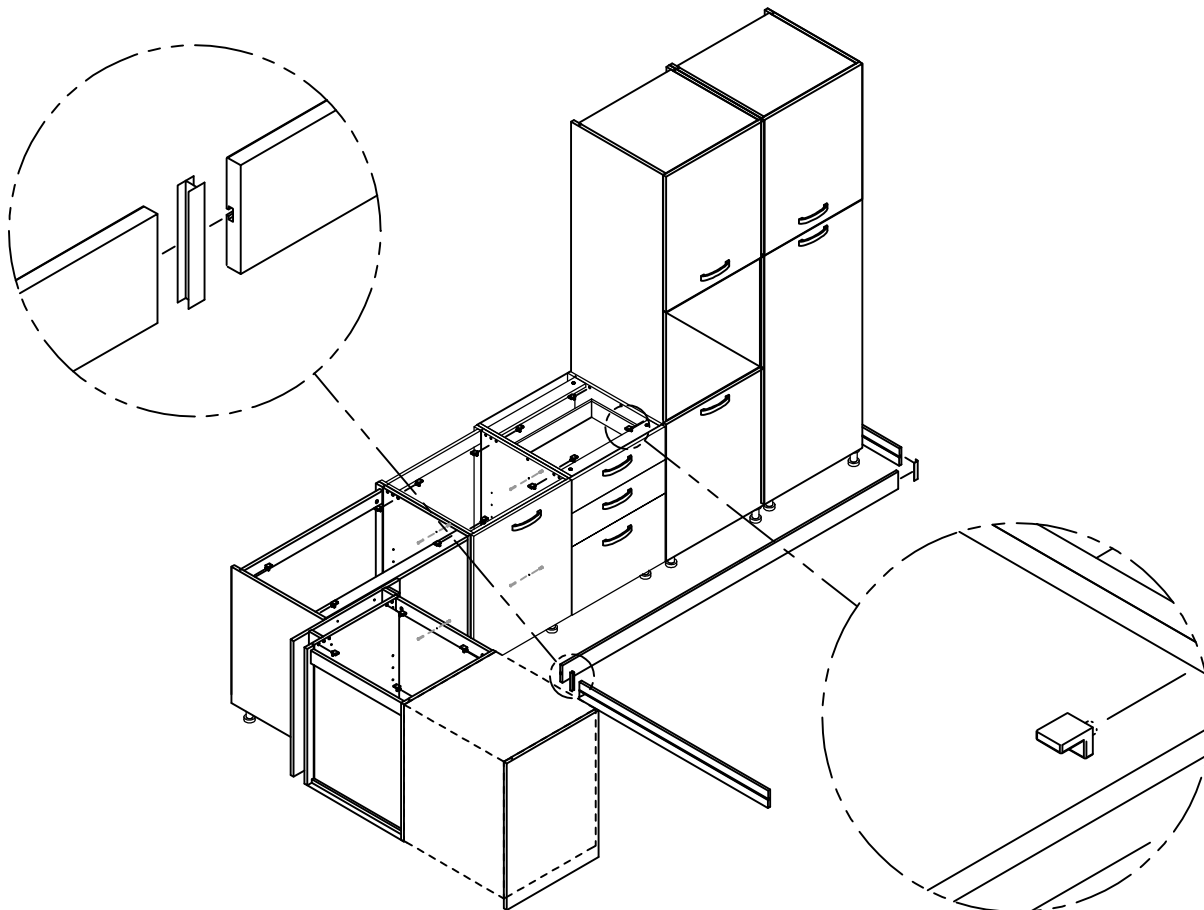
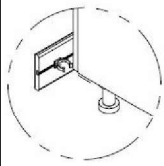
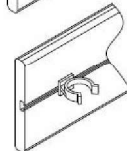
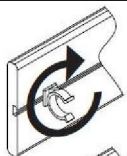
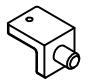

X 16 INR



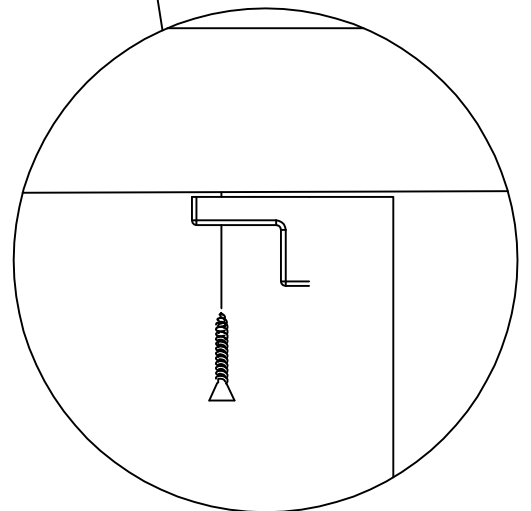
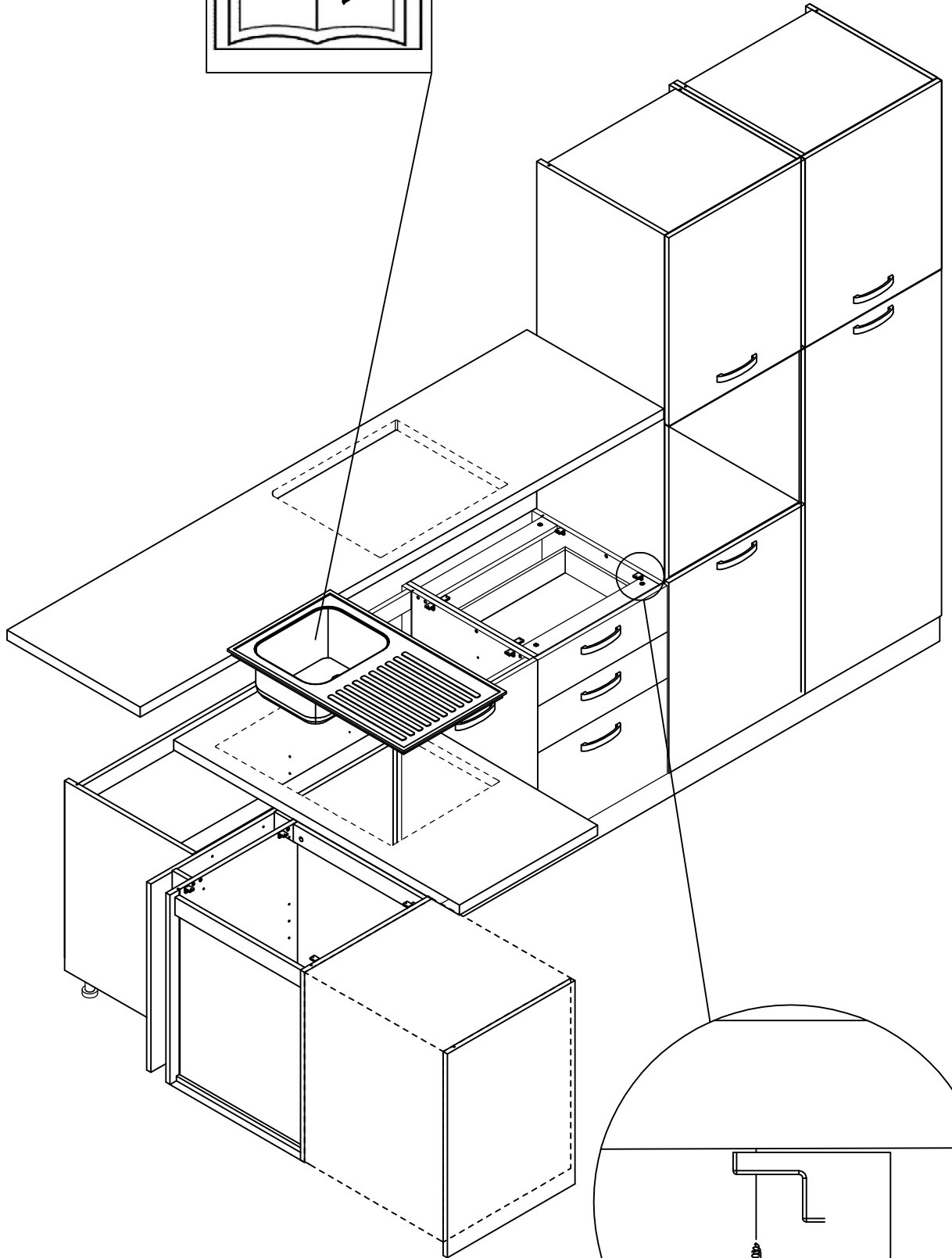
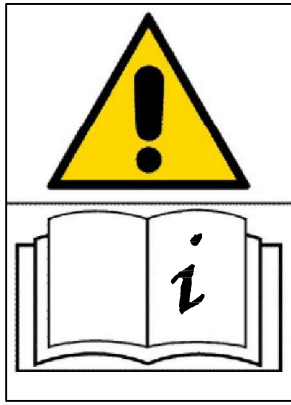

FFVAN2050
4x25

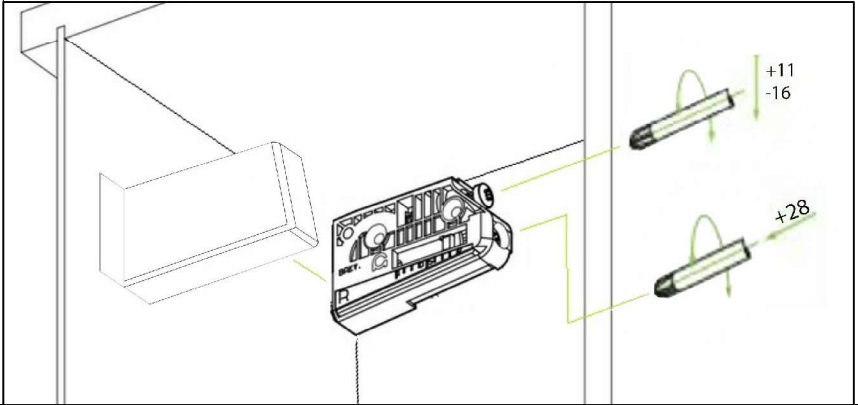
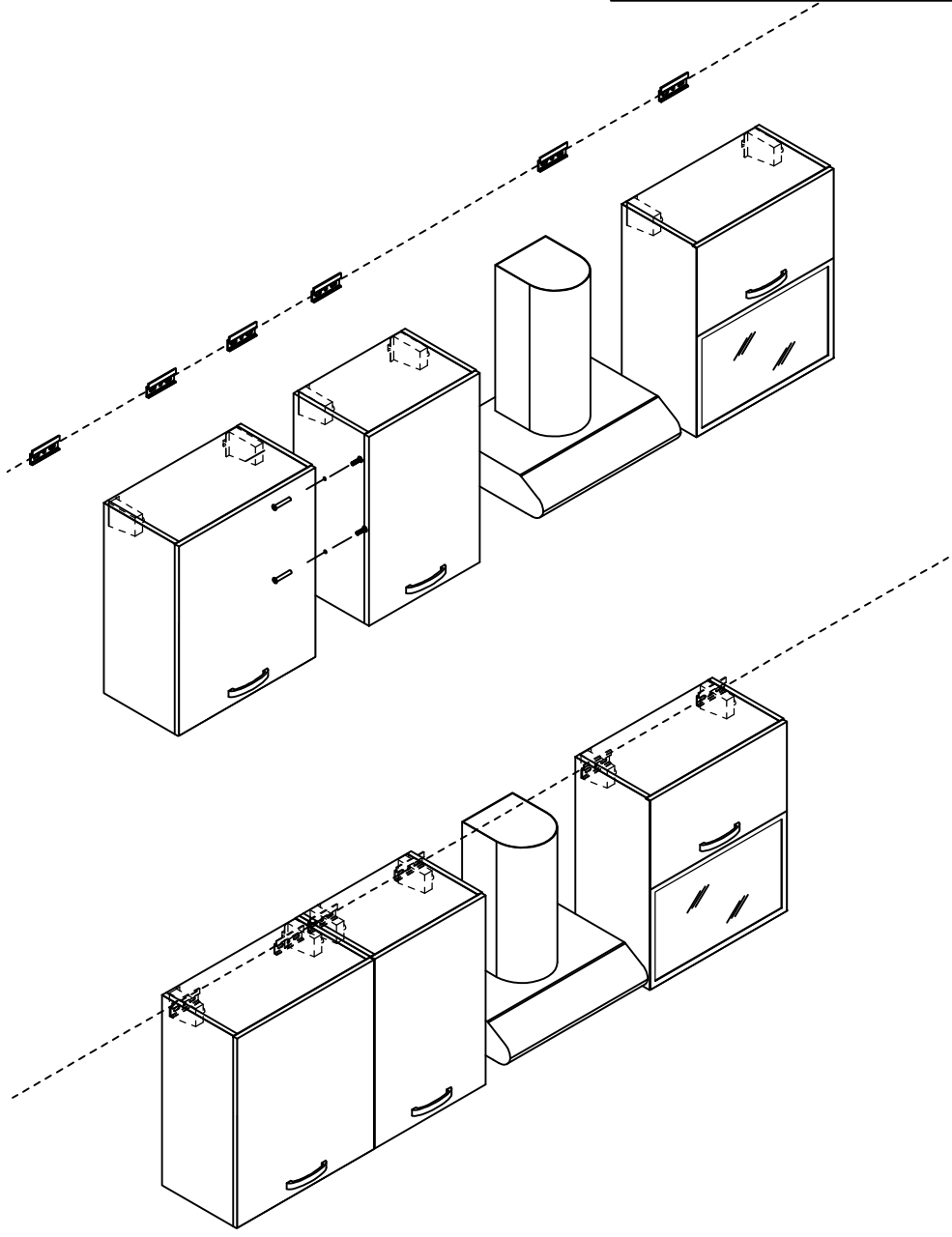
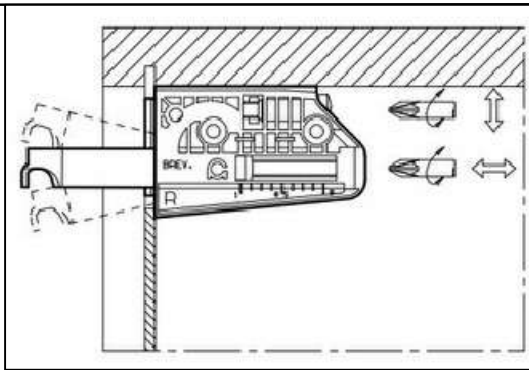

- X 2 NR
FFGPN2226
- X 6 NR
FFBAR5007
- X 3 NR
Z-ATTA02
- X 3 NR
Z-ATTA01
- X 3 NR
FFMAN2081
- X 6 NR
FFVAN2018
4MAX22

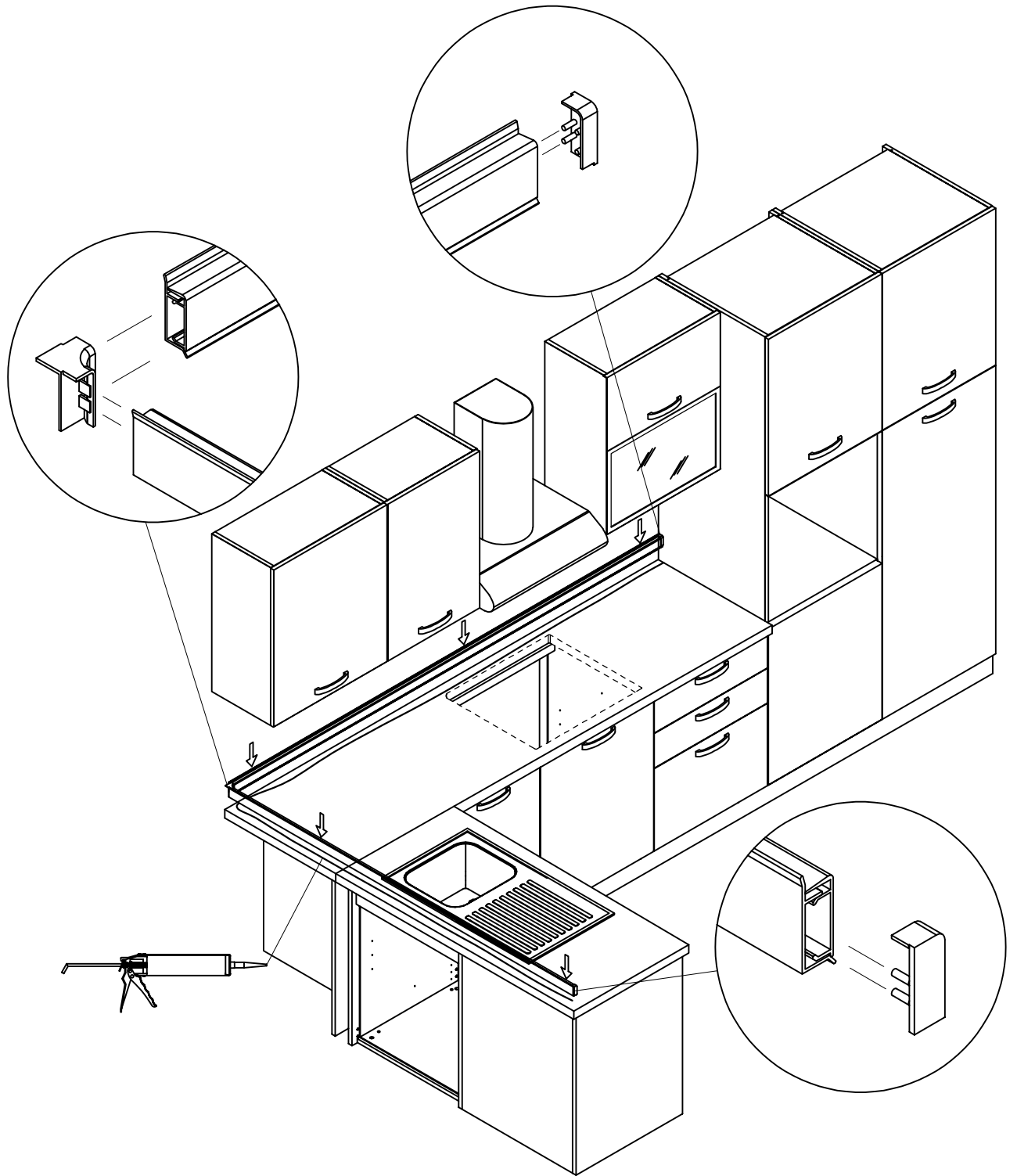

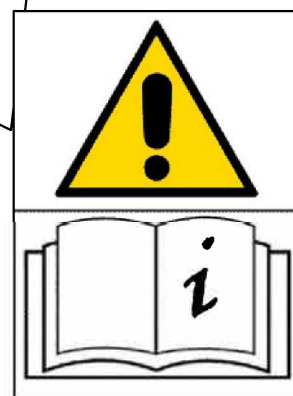
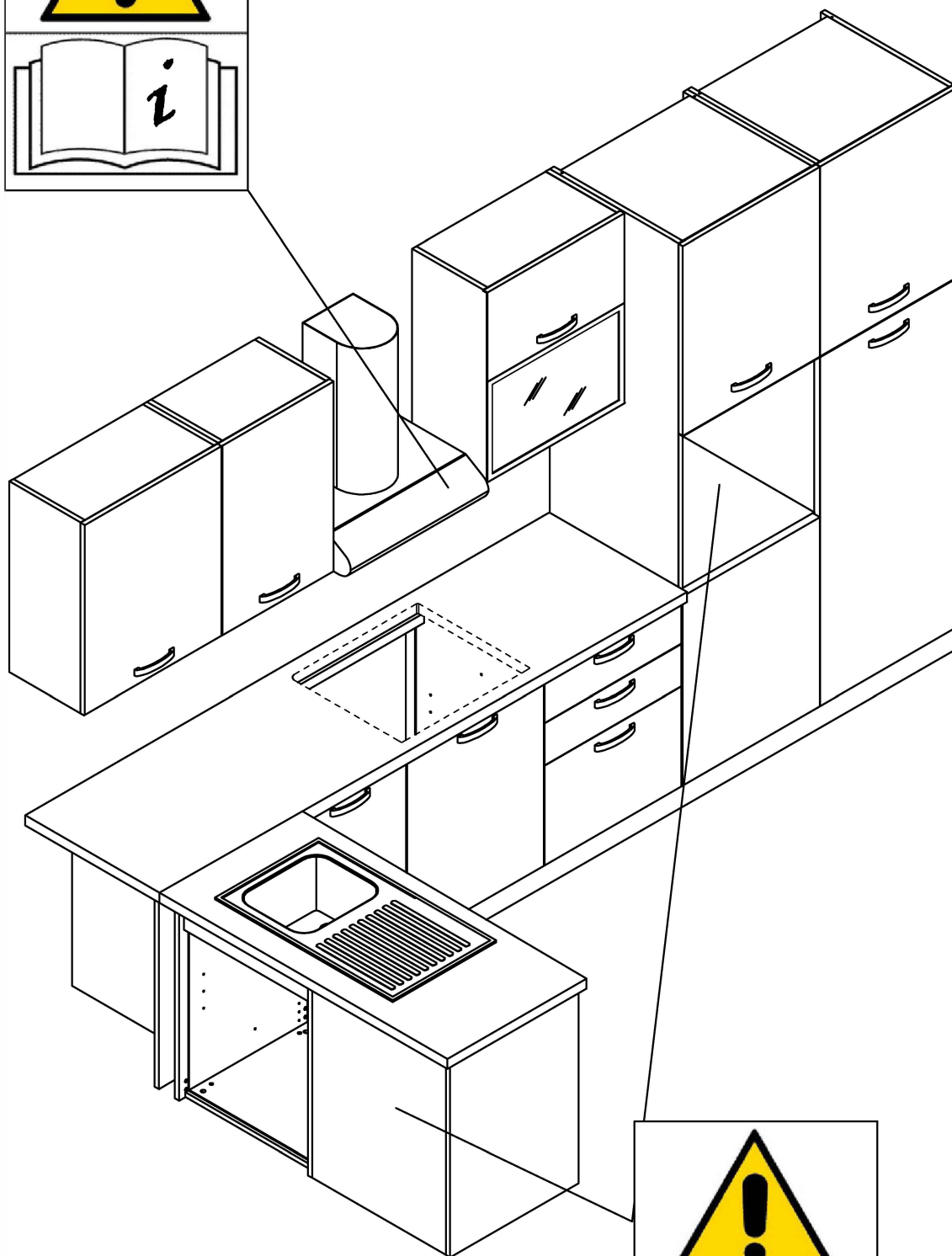
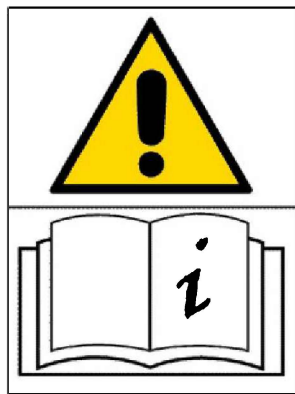



Candy (Haier Europe)

- **Croazia** (Centar za pomoć / Servis): https://www.candy-home.com/hr_HR/gdje-kupiti/
- **Slovenia** (Center za pomoč): https://www.candy-home.com/sl_SI/kje-smo/
- **Romania** (Centru de asistentă): https://www.candy-home.com/ro_RO/cere-asistenta/
- **Europa (Home)**: <https://www.haier-europe.com>

Beko

- **Romania** (Centru de asistentă): <https://www.beko.com/ro-ro/support/contact>
- **Croazia** (Korisnička podrška): <https://www.beko.com/hr-hr/support/help-center>
- **Serbia** (Korisnička podrška / Servisni centar): <https://www.beko.com/rs-sr/PodrSka/obratite-nam-se>