

ARES

ARES S.r.l.
Zona artigianale "Gli Ulivi"
Sestino (AR)
www.aresmobilitificio.it

IT ISTRUZIONI DI MONTAGGIO
GB ASSEMBLING INSTRUCTIONS
FR NOTICE DE MONTAGE
SLO NAVODILA ZA MONTAŽO
SRB UPUTSTVO ZA MONTAŽU

D MONTAGEANLEITUNG
ES INSTRUCCIONES DE MONTAJE
P INSTRUCOES DE MONTAGEM
HR UPUTE ZA MONTAZU
RO FOAIE CU INSTRUCIUNI
BG ИНСТРУКЦИИ ЗА СГЛОБЯВАНЕ

COD:0WMMTI066BSCTS

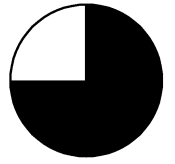
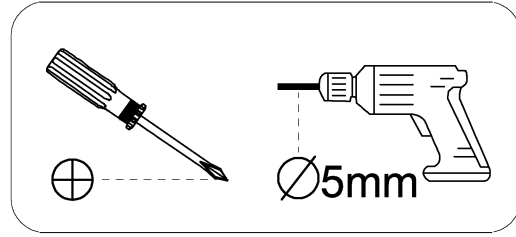
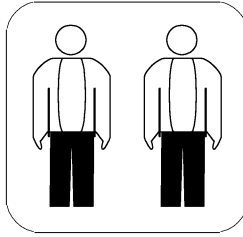
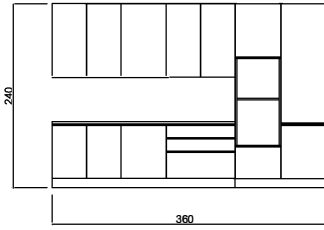

120 MIN

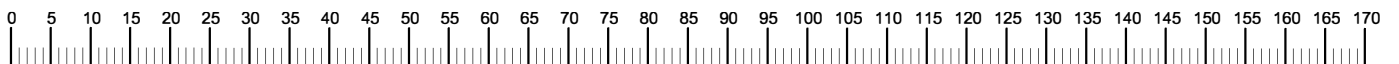
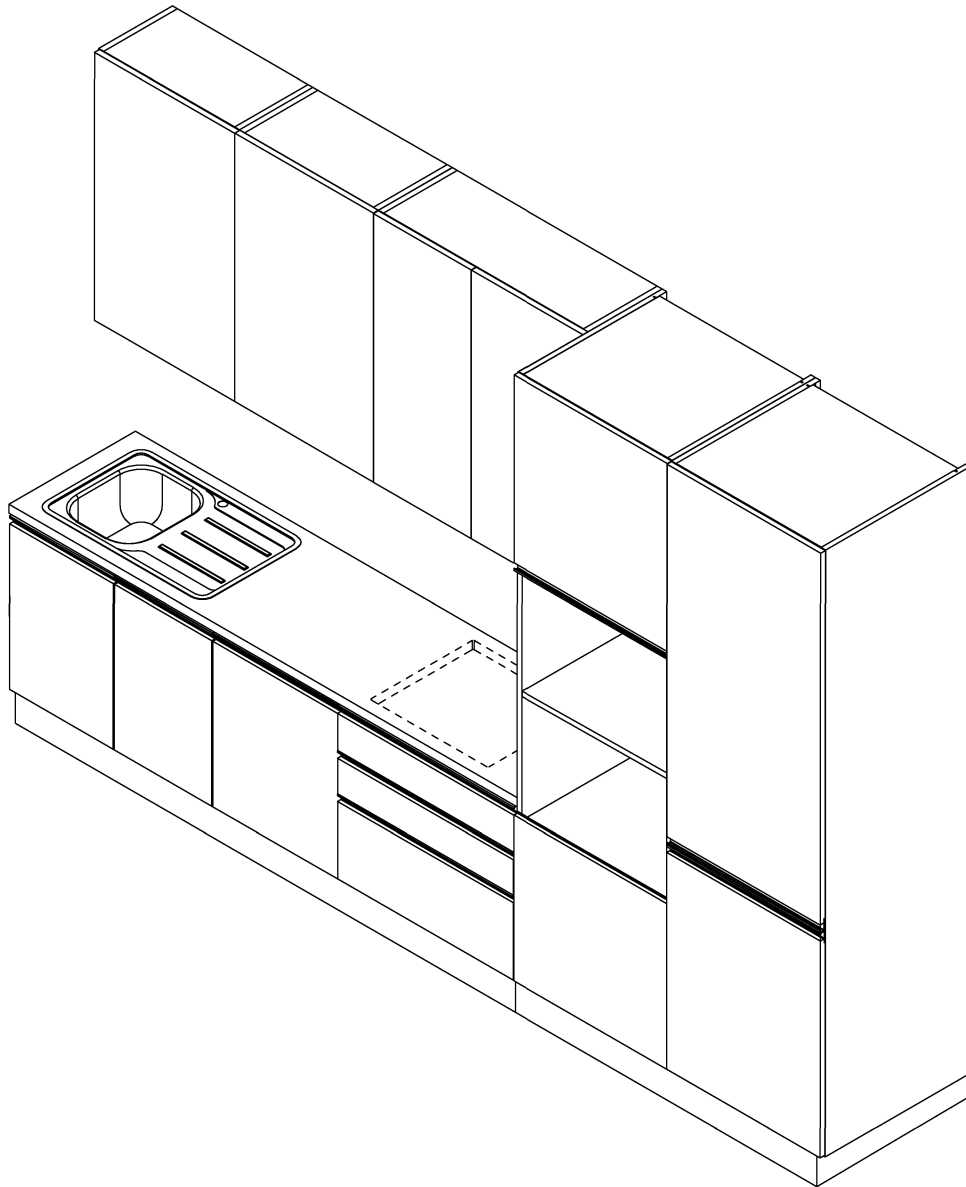

Française – Suisse

CONSEILS DE MONTAGE

1. Bien étudier la notice de montage;
2. Repérez les pièces constituant votre meuble;
3. Regroupez et contrôlez la quincaillerie;
4. Munissez-vous de l'outillage nécessaire;
5. Aménagez-vous une zone de montage;
6. Procédez au montage.

CONSEILS D'ENTRETIEN

1. Dépoussiérez soigneusement;
2. Humecter un chiffon doux et propre d'eau légèrement savonneuse (ou détergent)

 Ne jamais forcer les assemblages
Resserrez les vis après quelques temps d'usage
Garder votre notice de montage
Si une pièce devait a manquer, le plus simple est de contacter votre magasin directement
Le poids maximum autorisé sur les boîtes de tiroir est de 10 kg

Ne jamais utiliser de produits abrasifs:
poudre, laine d'acier, solvants

English

ASSEMBLING ADVICE

1. Study careful the assembly instructions;
2. Characterize pieces that form the furniture;
3. Group and control the ironware;
4. Take the necessary tools for the assembly;
5. Prepare an assembly zone;
6. Proceed with the assembly.

MAINTENANCE ADVICE

1. Dust accurately;
2. Damp a cleaned and soft cloth with water and little detergent.

 Never force the assemblages
Screw the screws after a long period
Conserve the assembly instructions
If one or more pieces are missing, please contact the store
Maximum weight allowed on drawer boxes is 10kg.

Do not use abrasive products: powder, steel wool, solvents

Italiano – Svizzera

CONSIGLI DI MONTAGGIO

1. Studiare bene le istruzioni di montaggio;
2. Controllare che tutti i pezzi che costituiscono il mobile siano presenti;
3. Raggruppare e controllare la ferramenta;
4. Munirsi degli utensili necessari al montaggio;
5. Allestire una zona di montaggio;
6. Procedere al montaggio.

CONSIGLI PER LA MANUTENZIONE

1. Spolverare accuratamente;
2. Inumidire con acqua leggermente insaponata uno straccio morbido e pulito.

 Non forzare mai gli assemblaggi
Stringere le viti dopo un periodo d'uso
Conservare le istruzioni di montaggio
Se un pezzo dovesse mancare o essere rotto, contattare il punto vendita
Il peso massima supportato dai cassetti è di 10kg.

Non utilizzare mai prodotti abrasivi:
polvere, lana di acciaio, solventi

Deutsch – Schweiz

MONTAGE ANLEITUNG

1. Die Montageanleitung genau durchlesen;
2. Die Einzelteile des Möbels stück ermitteln;
3. Die Beschläge zusammenlegen und prüfen;
4. Das Notwendige werkzeug zurechtlegen;
5. Einem Montagebereich freimachen;
6. Das Möbels stück zusammenbauen.

PFLEGEHINWEISE

1. Sorgfältig entstauben;
2. Mit einem weichen, sauberen und feuchtem Tuch und leichter selfentaue reinigen

 Niemals die Verbindungen zu stark anziehen
Die Schrauben nach Lang Zeit des Gebrauchs erneut festziehen
Die Montageanleitung gut aufbewahren
Wenn ein Teil fehlen, ist Sie das beste Verständigungsmittel mit Ihrem Geschäft
Das maximale Gewicht auf Schubladenkästen erlaubt ist 10 kg

Benutzen Sie keine Scheuermittel wie
Pulver, Stahlwolle, Lösungsmittel

Español

CONSEJOS PARA EL MONTAJE

1. Estudie atentamente el manual de montaje;
2. Localice las piezas que constituyen su mueble;
3. Reuna y controle los tornillos;
4. Equipese de las herramientas necesarias;
5. Prepare una zona de montaje;
6. Realice el montaje.

CONSEJOS PARA EL MANTENIMIENTO

1. Despolvorear cuidadosamente;
2. Humedecer un paño suave y limpio con agua ligeramente enjabonada.

Portugues

CONSELHOS DE MONTAGEM

1. Estuda bem as instruções de montagem;
2. Junta as peças que constituem o seu móvel;
3. Reagrupa e controla a quinquilharia;
4. Equipa-se da ferramenta necessária;
5. Cria-se uma zona de montagem;
6. Proceda á montagem.

CONSELHOS DE MONTAGEM

1. Eliminar bem o pó;
2. Umedecer um pano suave e limpo com água e um pouco de sabão.

Hrvatski

SAVJETI ZA MONTAZU

1. Porucite pažljivo upute za montazu;
2. Prekontrolirajte po uputama da li imate sve dijelove;
3. Prekontrolirajte da li imate sve vijke, matice i ostale metalne dijelove;
4. Osigurajte potreban alat za sastavljanje;
5. Oslobodite odgovarajući prostor za montiranje;
6. Ukoliko ste provjerili sve gore navedeno možete započeti montazu.

SAVJETI ZA ODRZAVANJE

1. Uklanjajte redovito prasinu i nečistoće;
2. Cistite uvijek s malo vode i blagog deterdženta te mekom i čistom krpom.

SLOVENŠČINA

NAVODILA ZA MONTAŽO

1. Pozorno preberite navodila za montažo;
2. Določite posamezne dele pohištva;
3. Preverite, ali imate vse vijake, matice in ostale kovinske dele;
4. Pripravite potrebna orodja;
5. Pripravite in počistite prostor, kjer boste pohištvo sestavljali;
6. Sestavite pohištvo.

NAVODILA ZA NEGO

1. Redno brišite prah.
2. Očistite z mehko, čisto in vlažno krpo ter uporabite malo milnice.



No fuerce nunca en las uniones
Apriete los tornillos despues de cierto tiempo de utilizacion
Conserve su manual de montaje
Si faltara una pieza, seia la manera mas facil de comunicar con la tienda
El peso máximo permitido en las cajas de cajón es de 10 kg



No use nunca productos abrasivos tales como: polvo de limpiar, lana de acero, solventes.



Nunca esforçar as montagem
Apertar os pafusos após un tempo de utilização
Guardar as instruções de montagem, si faltara alguna pieza, lo mas aconsejable es contactar con la tienda
O peso máximo permitido em caixas de gaveta é de 10 kg

Nunca utilizar productos abrasivos pos, la de aço, solventes



Prilikom montiranja, nemojte nasilno pokušavati spojiti dijelove
Odvijati vijke nakon duzeg stajanja montiranog proizvod
Ukoliko Vam nedostaje koji dio, molimo Vas kontaktirajte trgovinu u kojoj ste namjestaj kupili
Ladica ima nosivost od maksimalnih 10kg

Nemojte koristiti abrazivne krpe, pudere, matalnu vunu ili sredstva koja mogu otopiti površinu namjestaja



Delov ne zategujte preveč.
Po daljšem času ponovno zategnite vijake.
Navodila za montažo hranite na varnem mestu.
Če kakšen del manjka, kontaktirajte prodajalno, v kateri ste pohištvo kupili.
Predali imajo največjo nosilnost 10 kg.

Ne uporabljajte abrazivnih krp, praškov, jeklene volne ali sredstev, ki lahko raztopijo površino pohištva.



БЪЛГАРСКИ

СЪВЕТ ЗА МОНТАЖ

1. ПРОУЧЕТЕ ВНИМАТЕЛНО ИНСТРУКЦИИТЕ ЗА СГЛОБИКА;
2. ПРОВЕРЕТЕ ДАЛИ ВСИЧКИ ЧАСТИ, КОИТО СЪСТАВЛЯВАТ МЕБЕЛИТЕ ПРИСЪСТВАТ;
3. ПРОВЕРЕТЕ ДАЛИ ИМАТЕ ВСИЧКИ В ВИНТОВЕ, ГАЙКИ И ДРИГУ МЕТАЛНИ ЧАСТИ;
4. ОСИГУРЕТЕ НЕОБХОДИМИТЕ ИНСТРУМЕНТИ ЗА СГЛОБИАВАНЕТ;
5. ОСВОБОДЕТЕ ПОДХОДЯЩО МЯСТО ЗА МОНТАЖ;
6. ПРОДЪЛЖЕТЕ КЪМ СГЛОБИАВАНЕТО;

СЪВЕТ ЗА ПОДДРЪЖКА

1. ПОЧИСТЕТЕ СТАРАТЕЛНО ОТ ПРАХ;
2. НАВЛАЖНЕТЕ МЕК ЧИСТ ПАРЦАЛ С ЛЕКО САПУНЕНА ВОДА.



НИКАКЪВ СЛУЧАЙ НЕ ПРЕНАТЯГАЙТЕ. СЛЕД ДЪЛГО ВРЕМЕ **СТЯГАМ** ОТНОВО **ВИНТОВЕТЕ**. ПАЗЕТЕ ИНСТРУКЦИИТЕ ЗА СГЛОБИАВАНЕ
АКО НЯКОЯ ЧАСТ **ЛИПСВА** ИЛИ Е СЧУПЕНА **СВЪРЖЕТЕ** СЕ МАГАЗИНА ОТ КОИТО СТЕ ЗАКУПИЛИ МЕБЕЛИТЕ **МАКСИМАЛНО** ТЯЛО ПОДДЪРЖАНО ОТ ЧЕКМЕДЖЕТО Е **10KG**

НЕ ИЗПОЛЗВАЙТЕ АБРАЗИВНИ ПРОДУКТИ: ПРАХ, СТОМАНЕНА ВАТА, РАЗТВОРИТЕЛИ

ROMANIA

SFATURI DE MONTAJ

1. Studiați cu atenție instrucțiunile de asamblare;
2. Verificați dacă toate piesele care compun mobilierul sunt prezente;
3. Grupați și verificați hardware-ul;
4. Echipați-va cu sculele necesare asamblării;
5. Amenajează o zonă de asamblare;
6. Continuați cu asamblarea.

SFATURI DE ÎNTREȚINERE

1. Curățați praful bine;
2. Umeziți cu apă ușor săpun o cârpă moale și curată.



Nu forțați niciodată ansamblurile. Strângeți șuruburile după o perioadă de utilizare. Păstrați instrucțiunile de asamblare. Dacă o piesă lipsește sau este ruptă, contactați punctul de vânzare. Greutatea maximă suportată de sertare este de 10 kg.

Nu utilizați niciodată praf abraziv, lână de sticlă sau solvenți.

SRPSKI

UPUTSTVO ZA MONTAŽU

1. PAŽLJIVO PROČITAJTE UPUTSTVO ZA MONTAŽU;
2. PREKONTROLIŠITE PREMA UPUTSTVU DA LI IMATE SVE POTREBNE DELOVE;
3. PREKONTROLIŠITE DA LI IMATE SVE ŠRAFOVE, MATICE I OSTALE METALNE DELOVE;
4. OSUGURAJTE POTREBAN ALAT ZA SASTAVLJANJE;
5. PRIPREMITE ODGOVARAJUĆI PROSTOR ZA MONTIRANJE;
6. UKOLIKO STE PROVERILI SVE GORE NAVEDENO MOŽETE ZAPOČETI MONTAŽU.



PRILIKOM MONTIRANJA NE POKUŠAVATI NASILNO SPAJANJE DELOVA. NAKON DUŽEG VREMENA KORIŠĆENJA PROIZVODA, ŠRAFOVE PONOVNO PRIČVRSTITI. UKOLIKO VAM NEDOSTAJE ODREĐENI DEO, MOLIMO VAS DA KONTAKTIRATE PRODAJNI CENTAR GDE STE NAMEŠTAJ KUPILI. FIOKA IMA MASKIMALNU NOSIVOST 10 KG.

NE KORISTITI ABRAZIVNE KPPE, PUDERE, ČELIČNU VUNU ILI SREDSTVA KOJA MOGU OŠTETITI POVRŠINU NAMEŠTAJA.

SAVETI ZA ODRŽAVANJE

1. UKLANJAJTE REDOVNO PRAŠINU I NEČISTOĆU;
2. ODRŽAVANJE MEKOM I VLAŽNOM KRPOM UZ UPOTREBU BLAGOG DETERDŽENTA.

(FR) NOTICE DE MONTAGE
(ES) INSTRUCCIONES DE MONTAJE
(IT) FOGLIO DI ISTRUZIONI
(SLO) NAVODILA ZA MONTAŽO

(GB) ASSEMBLING INSTRUCTIONS
(P) INSTRUCOES DE MONTAGEM
(HR) UPUTE ZA MONTAZU
(D) MONTAGEANLEITUNG

IMPORTANTE: Per evitare il ribaltamento accidentale del mobile è obbligatorio il fissaggio a muro. I tasselli necessari per il collegamento mobile/muro, dipendenti dal tipo di muro, non sono compresi. Consultare uno specialista in caso di dubbi.

IMPORTANT: To avoid the accidental tip-over of the furniture, the fixing of the furniture on the wall is mandatory. The needed hardware for the junction wall/furniture, depending of the nature of the wall, is not provided. If any doubt, consult a specialist.

IMPORTANT: Pour éviter le basculement accidentel du meuble, la fixation du meuble au mur est obligatoire. La visserie nécessaire pour la jonction mur/meuble, dépendante de la nature du mur n'est pas fournie. En cas de doute, consulter un spécialiste.

WICHTIG: Um die versehentliche Trübung der Möbel zu vermeiden, ist die Befestigung der Möbel an der Wand obligatorisch. Die benötigte Hardware für die Verbindungswand / Möbel, je nach Art der Wand, ist nicht vorgesehen. Wenn irgendwelche Zweifel, konsultieren Sie einen Spezialisten.

IMPORTANTE: Para evitar el vuelco accidental de los muebles, la fijación de los muebles en la pared es obligatoria. El hardware necesario para la pared / los muebles de la unión, dependiendo de la naturaleza de la pared, no se proporciona. En caso de duda, consulte a un especialista.

IMPORTANTE: Para evitar a queda acidental do mobiliário, a fixação dos móveis na parede é obrigatória. O hardware necessário para a junção parede / móveis, dependendo da natureza da parede, não é fornecido. Em caso de dúvida, consulte um especialista.

VAŽNO: Da bi se izbjeglo slučajno tip-over namještaja, fiksiranje namještaja na zidu je obavezno. Potreban hardver fot na spoj zida / namještaja, ovisno o prirodi zida, nije predviđeno. Ako imate bilo kakve sumnje, konzultirati stručnjaka.

OPOZORILO:

Da ne bi pohištva prevrnili, je pritrditev pohištva na steno obvezna.

Deli, potrebni za pritrditev pohištva na steno, ki so odvisni od vrste stene, niso priloženi.

Če ste v dvomih, se posvetujte s strokovnjakom.

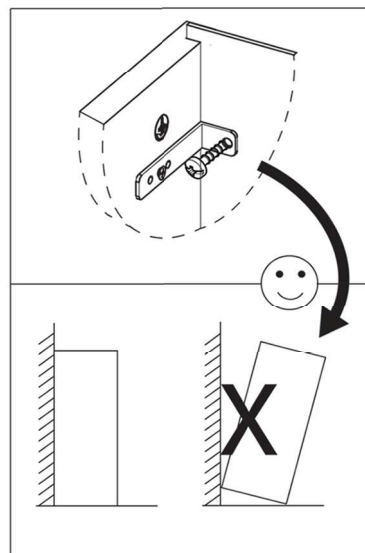

ARES

(IT) ISTRUZIONI DI MONTAGGIO
 (GB) ASSEMBLING INSTRUCTIONS
 (FR) NOTICE DE MONTAGE
 (SLO) NAVODILA ZA MONTAŽO
 (SRB) UPUTSTVO ZA MONTAŽU

(D) MONTAGEANLEITUNG
 (ES) INSTRUCCIONES DE MONTAJE
 (P) INSTRUCOES DE MONTAGEM
 (HR) UPUTE ZA MONTAZU
 (RO) FOAIE CU INSTRUCIUNI
 (BG) ИНСТРУКЦИИ ЗА СГЛОБЯВАНЕ

	Cod.	Parcel number	Size - mm.	Description	n.
1	8WEBEFF003D	8WEBEFF003D		FRIDGE	1
2	8WXXKEX6018	8WXXKEX6018		HOOD	1
3	8WEBEPC006	8WEBEPC006		HOB	1
4	8WXXLXO791S	8WXXLXO791S		SINK	1
5	8WEBEFO010	8WEBEFO010		OVEN	1
5-1	8WEBEMI001X	8WEBEMI001X		MICROWAVE	1

	Cod.	Parcel number	Size - mm.	Fridge column	n.
6-1	4WKTBI3CA004	2WMMBI6039	563X531X18	TOP	2
6-2	4WKTBI1BA004	2WMMBI6039	563X531X18	BOTTOM	1
6-3	PWXXTI3FD607	2WASTI6038	2280X560X18	RH SIDE	1
6-4	PWXXTI3FS607	2WASTI6038	2280X560X18	LH SIDE	1
6-5	4WELBS7SG904D	2WELBS6036D	596X1524X18	DOOR	1
6-6	4WELBS7SG604D	2WELBS6036D	596X684X18	DOOR	1
6-7	5MRBA2041	2WASTI6038	459X578X3	BACK	1
6-8	9WXXAPFA601	9WXXAPFA601		UNDER FRIDGE PROTECTOR	1

	Cod.	Parcel number	Size - mm.		n.
7	4WBRATTBB2464AT	2WBRATTBB2464	2402X600X38	TOP	1

	Cod.	Parcel number	Size - mm.		n.
8	2WGDITIPP909CT	2WGDITIPP909CT		WALL UNIT L.60 H.96	1
9	2WGDITIPKB909CT	2WGDITIPKB909CT		WALL UNIT L.90 H.96	1
10	2WGDITIPP609CTS	2WGDITIPP609CTS		WALL UNIT L.60 H.96	1

	Cod.	Parcel number	Size - mm.	Sink cabinet	n.
11-1	4WKTBI1BA006	2WMMTI6104	863X531X18	BOTTOM	1
11-2	4WELBS7SG603D	2WELBS6063	446X684X18	DOOR	1
11-3	9WXXAPLA901	9WXXAPLA901		UNDER SINK PROTECTOR	1
11-4	9WXXNC1FA130	2WMMTI6104	863X67X18	JOIN CHAIN	3
11-5	4WXXTI1FI201	2WMMTI6104	720X560X18	LH-RH SIDE	2
11-6	4WELBS7SG603S	2WELBS6063	446X684X18	DOOR	1

	Cod.	Parcel number	Size - mm.	Oven column	n.
12-1	4WXXBI1BA004	2WELBTICF359BSD	563X531X18	BOTTOM	1
12-2	4WXXTI5TR004	2WELBTICF359BSD	563X515X18	SHELF	3
12-3	4WXXBI3CA004	2WELBTICF359BSD	563X531X18	TOP	1
12-4	4WXXTI5FS607	2WELBTICF359BSD	2280X560X18	LH SIDE	1
12-5	4WXXTI5FD607	2WELBTICF359BSD	2280X560X18	RH SIDE	1
12-6	4WELBS7SG104S	2WELBTICF359BSD	596X768X18	DOOR	1
12-7	4WELBS7SG404D	2WELBTICF359BSD	596X444X18	DOOR	1
12-8	5MRBI2254	2WELBTICF359BSD	823X578X3	BACK PANEL	1
12-9	5MRBI2255	2WELBTICF359BSD	511X578X3	BACK PANEL	1

	Cod.	Parcel number	Size - mm.	Cabinet	n.
13	8WXXZAK502	8WXXZAK502		PLINT	1
14	8WXXZAK502	8WXXZAK502		BACKSPLASH	1
15	4WELBS7SG614	2WELBSJSL406		DISHWASHER DOOR	1
16	2WELTICCA907BS	2WELTICCA907BS		CABINET WITH DRAWERS	1
17	9WXXALZOC51	9WXXALZOC51		PLINT	1

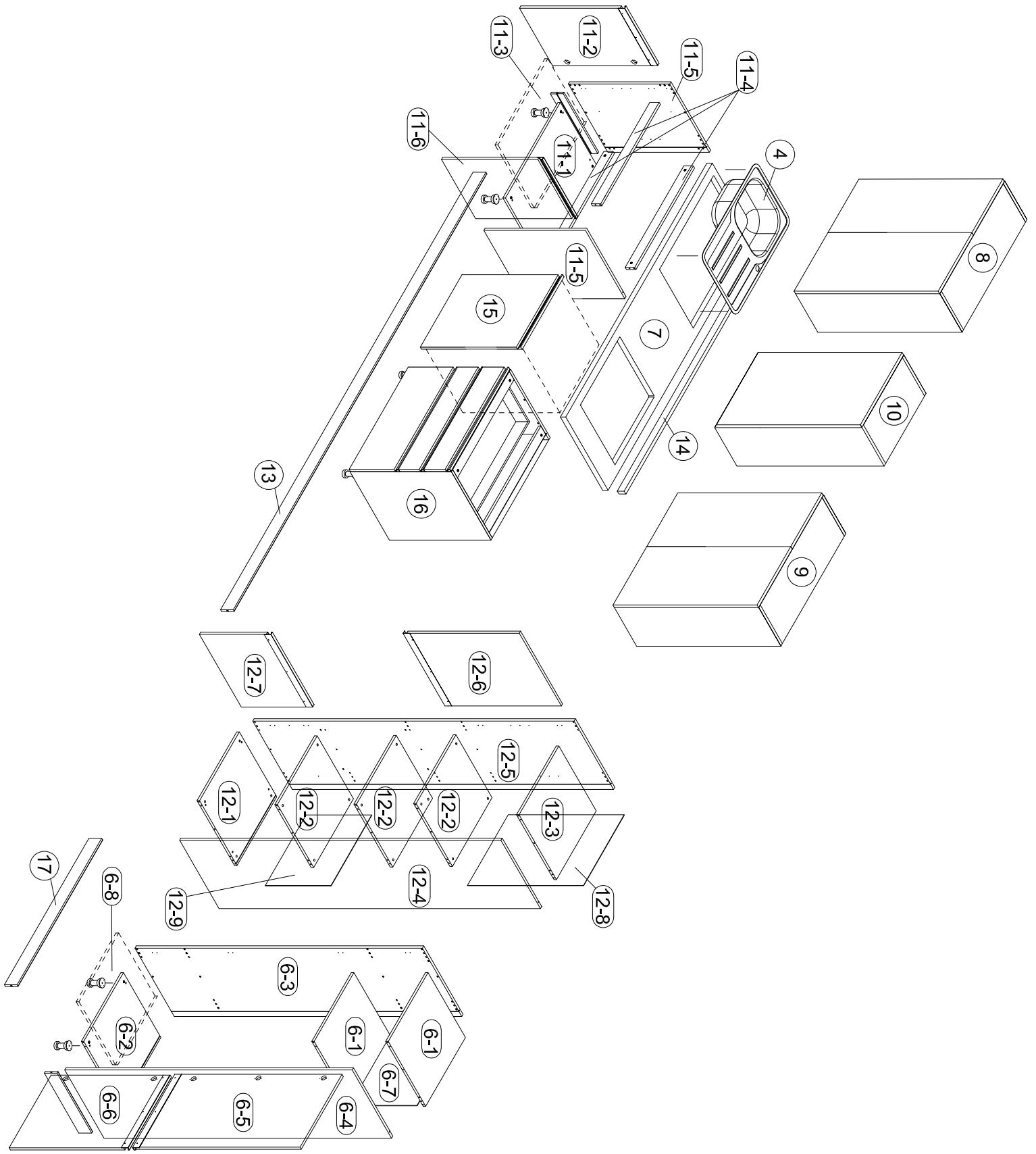

12 ^{NR}

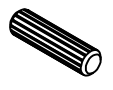

5SIFA2000

10 ^{NR}



FFMON2065

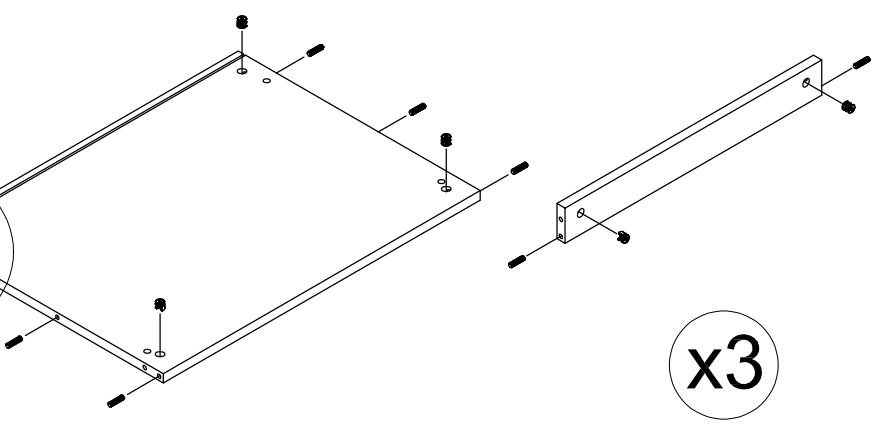
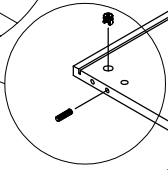
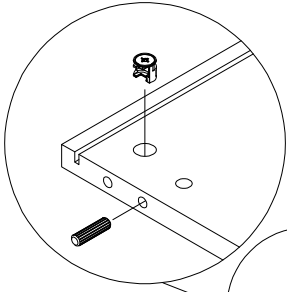

x3

10 ^{NR}



FFMON2051

4 ^{NR}



FFBMP2020

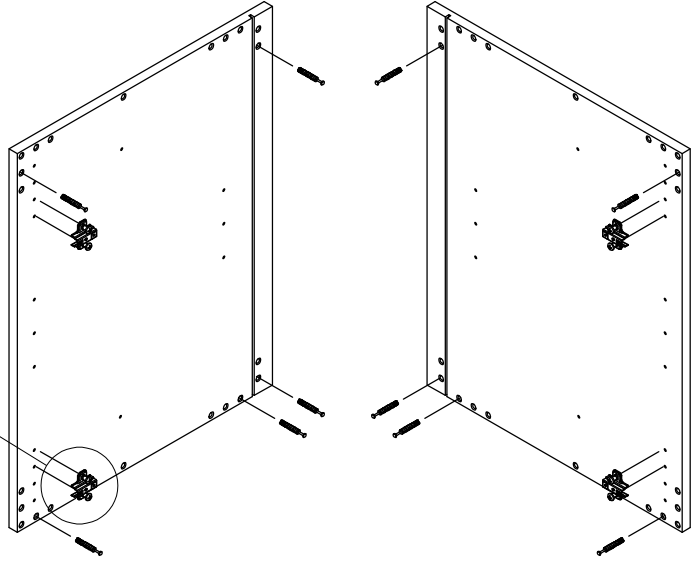
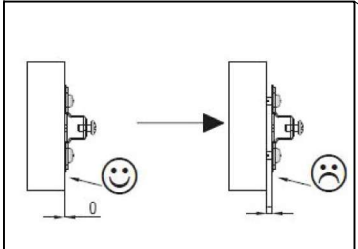

4 ^{NR}



8WXXAPBN01

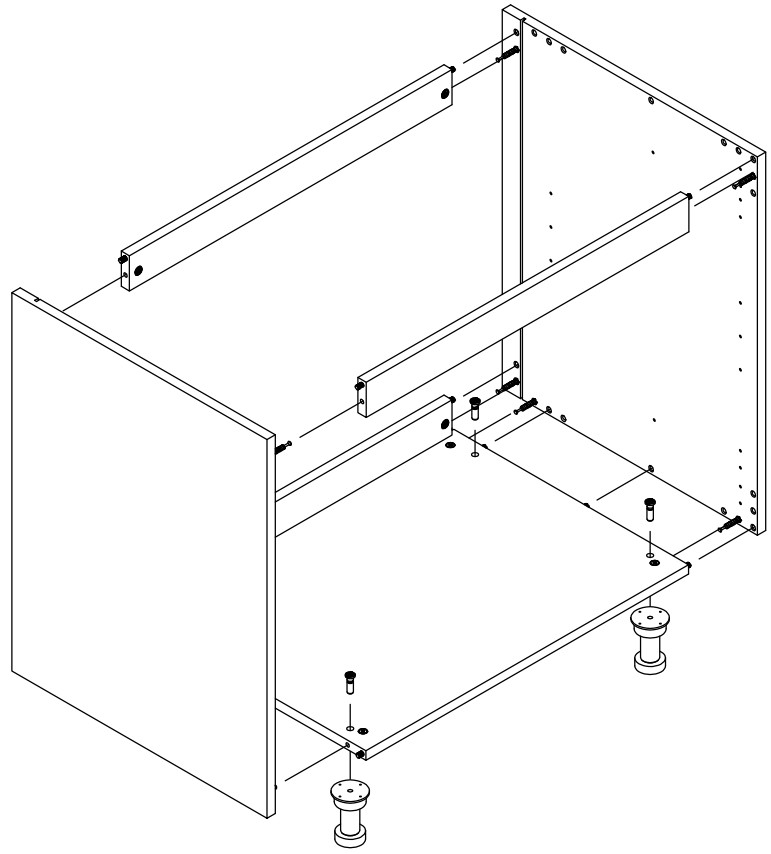

8

NR



FFVAN2056
3.5X15

4

NR

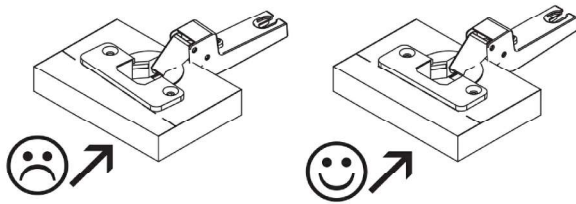
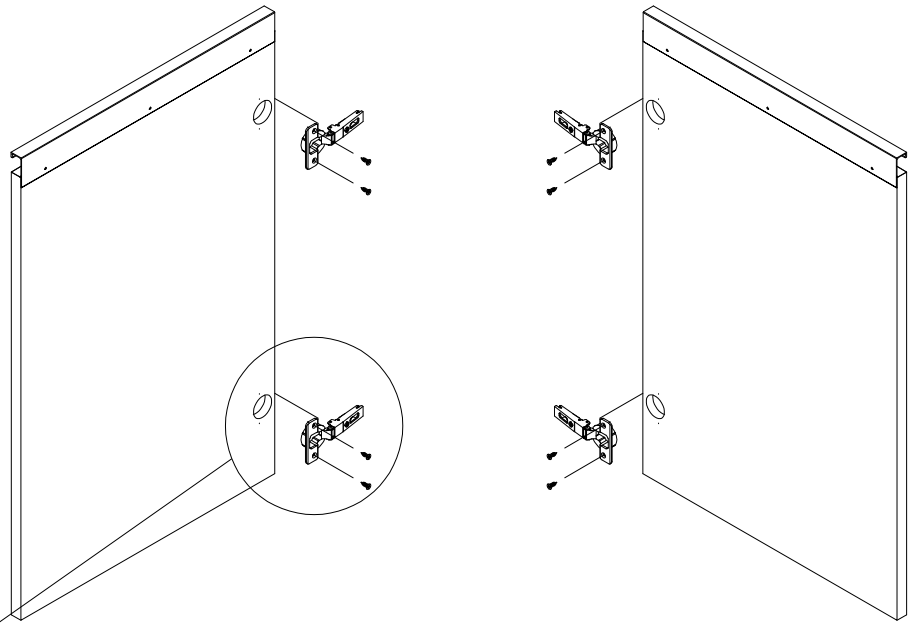
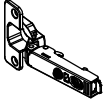

4

NR



FFPAR1050

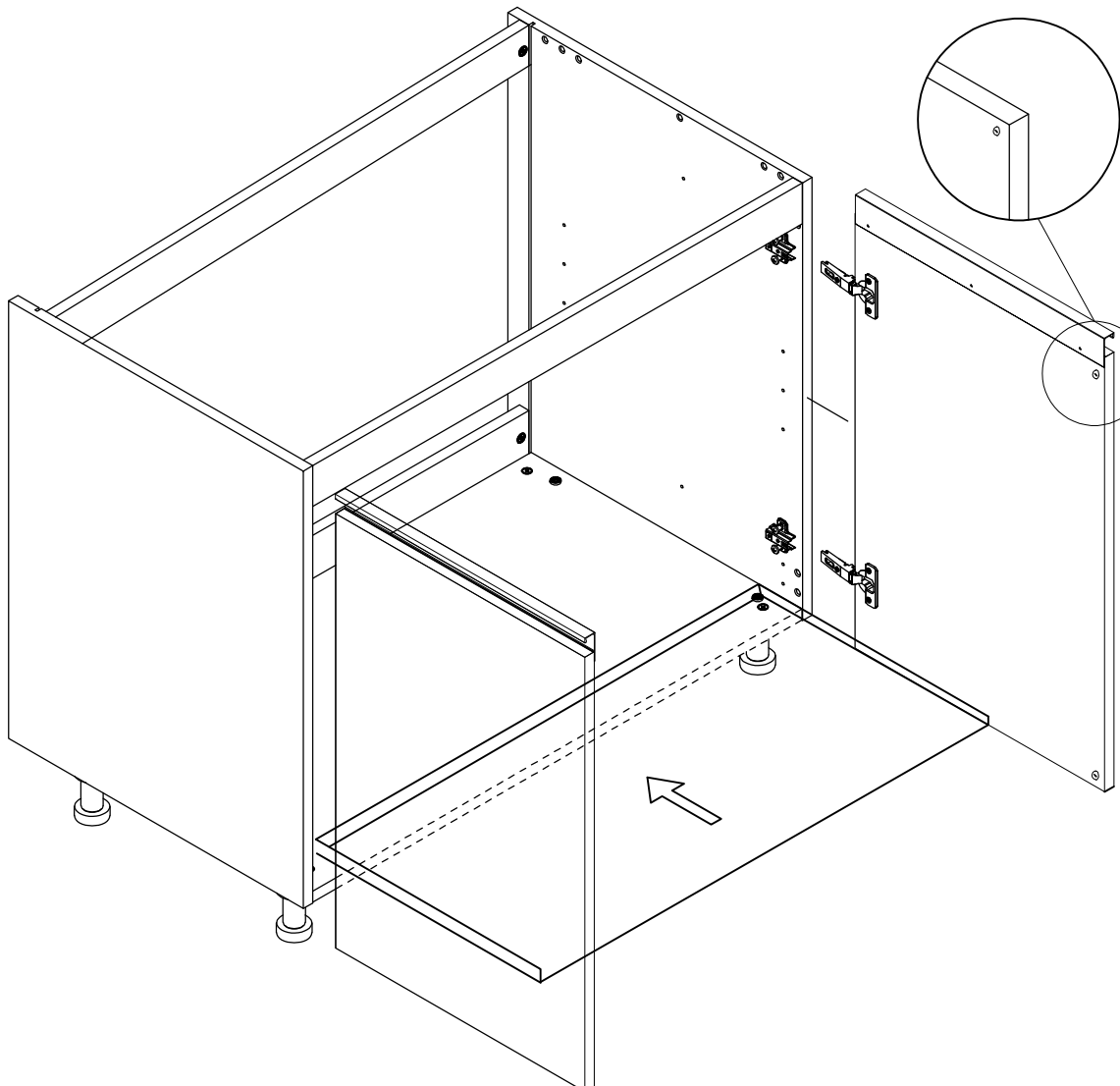
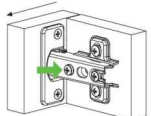
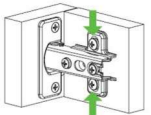
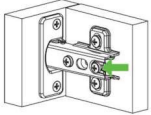

8 INR



FFMON2065

12 INR

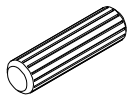

5SIFA2000

X2

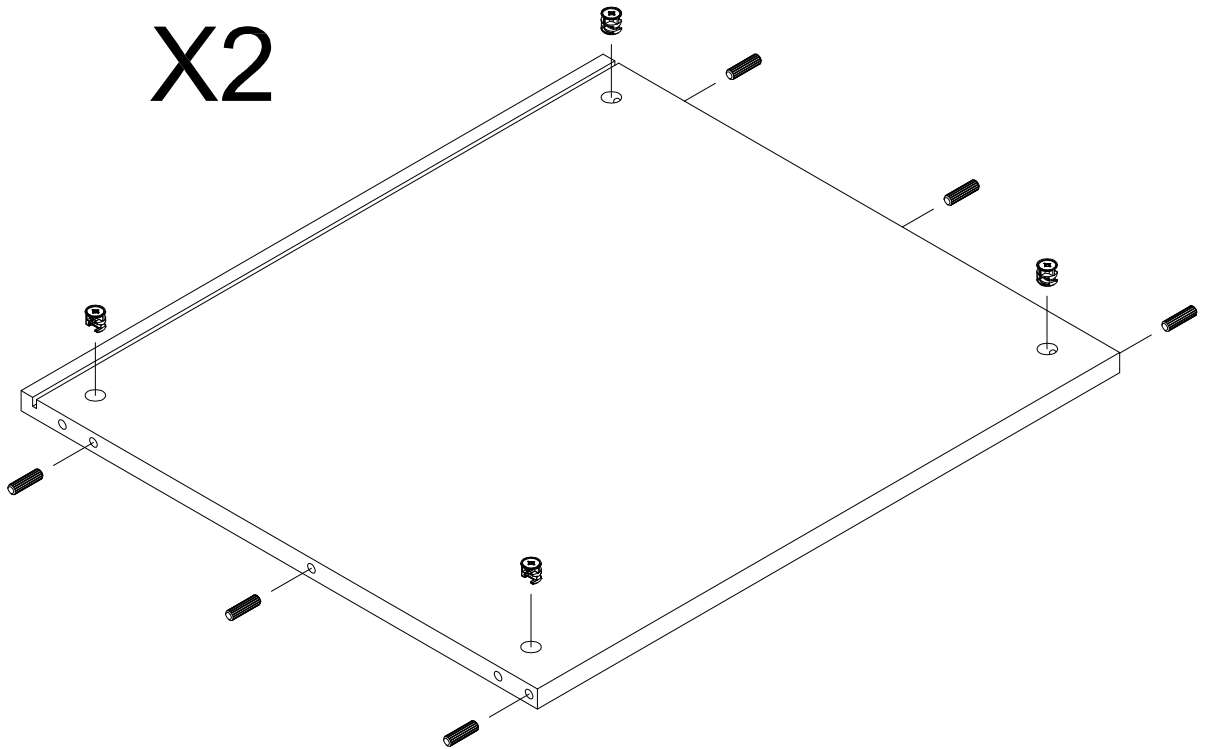

4 INR



FFMON2065

6 INR

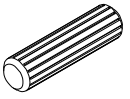

5SIFA2000

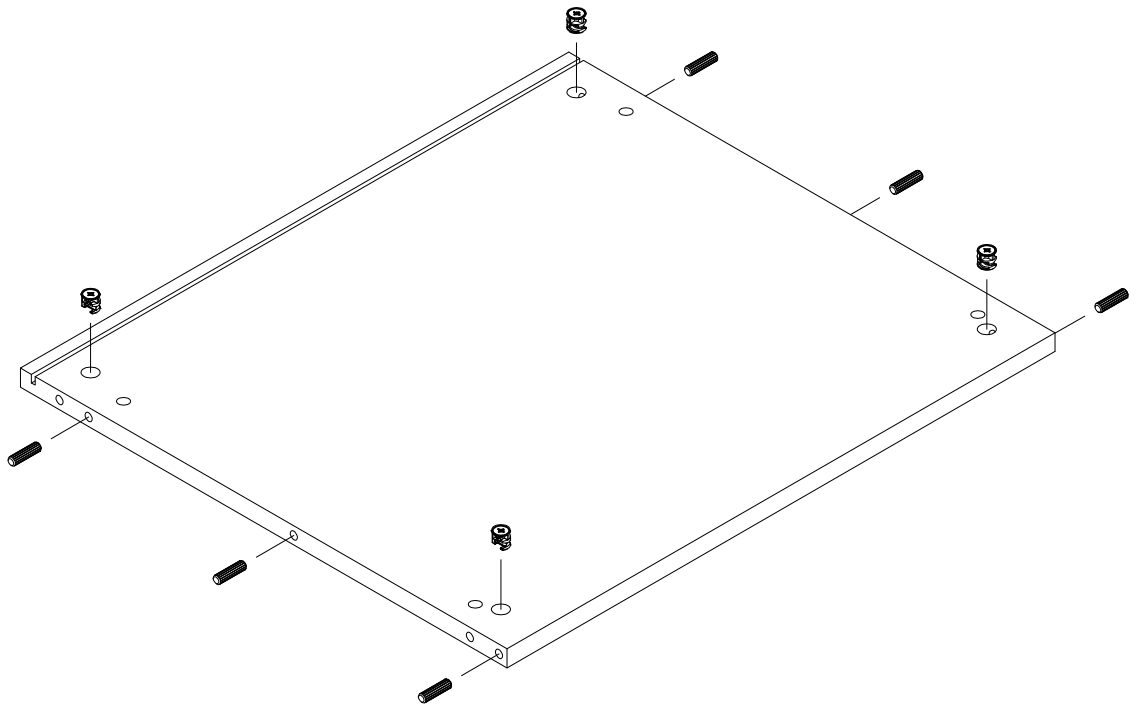

12 INR

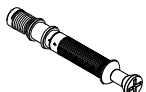

FFMON2083

5 INR



FFBMP2007

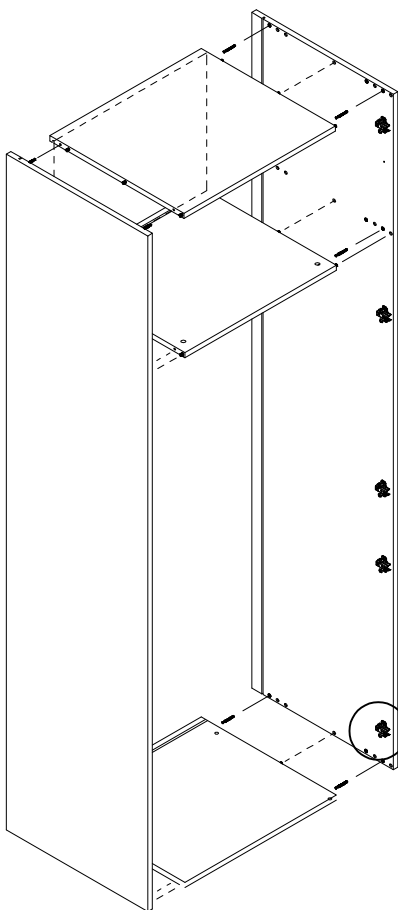
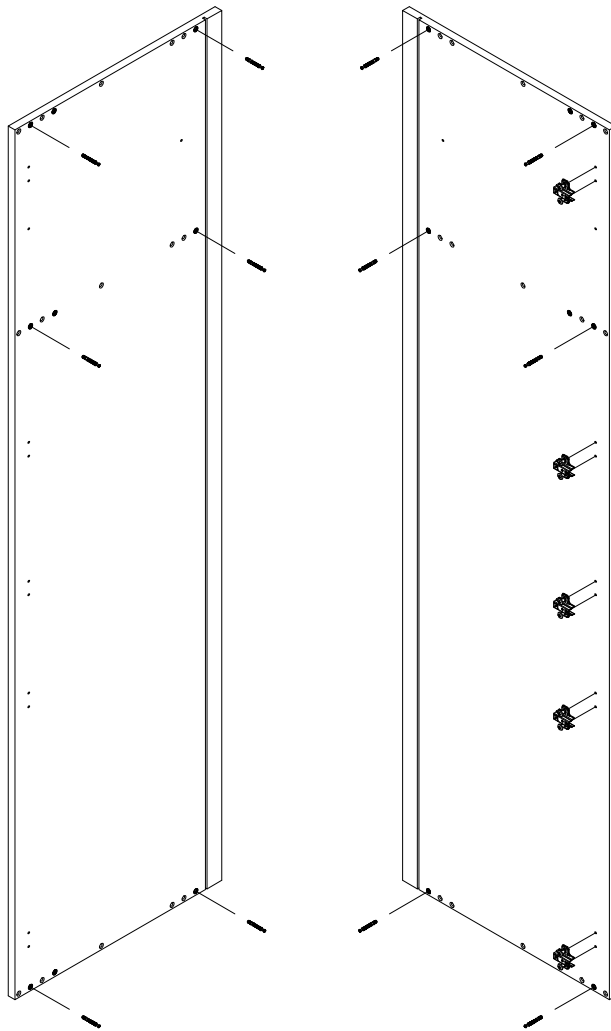

6 ^{NR}



FFSZ2007

2 ^{NR}



8SPFE4146

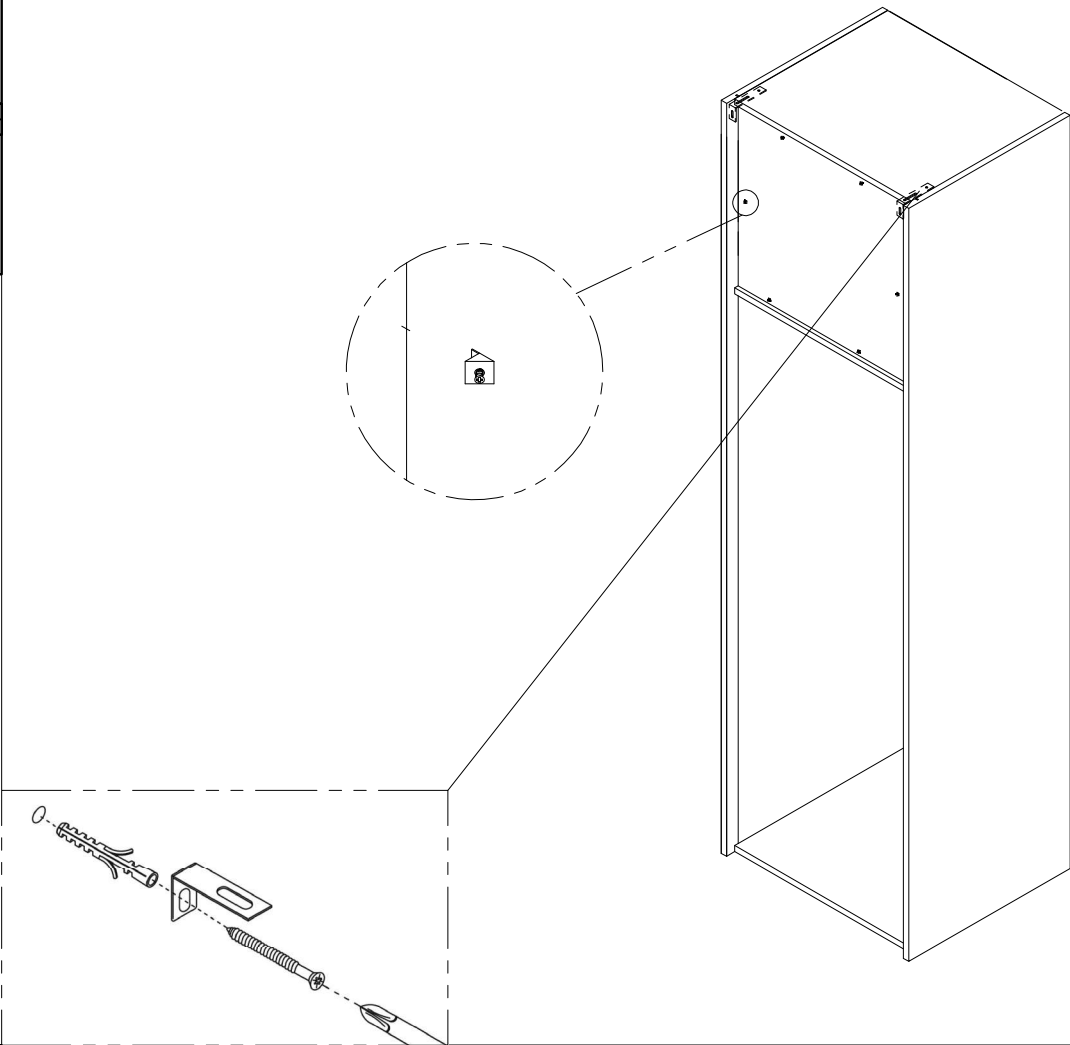

5 ^{NR}

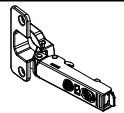

FFBMP2007

10 ^{NR}



FFVAN2056
3,5x15

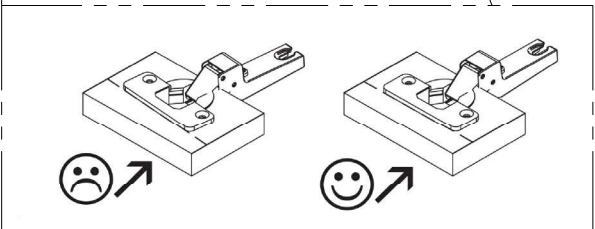
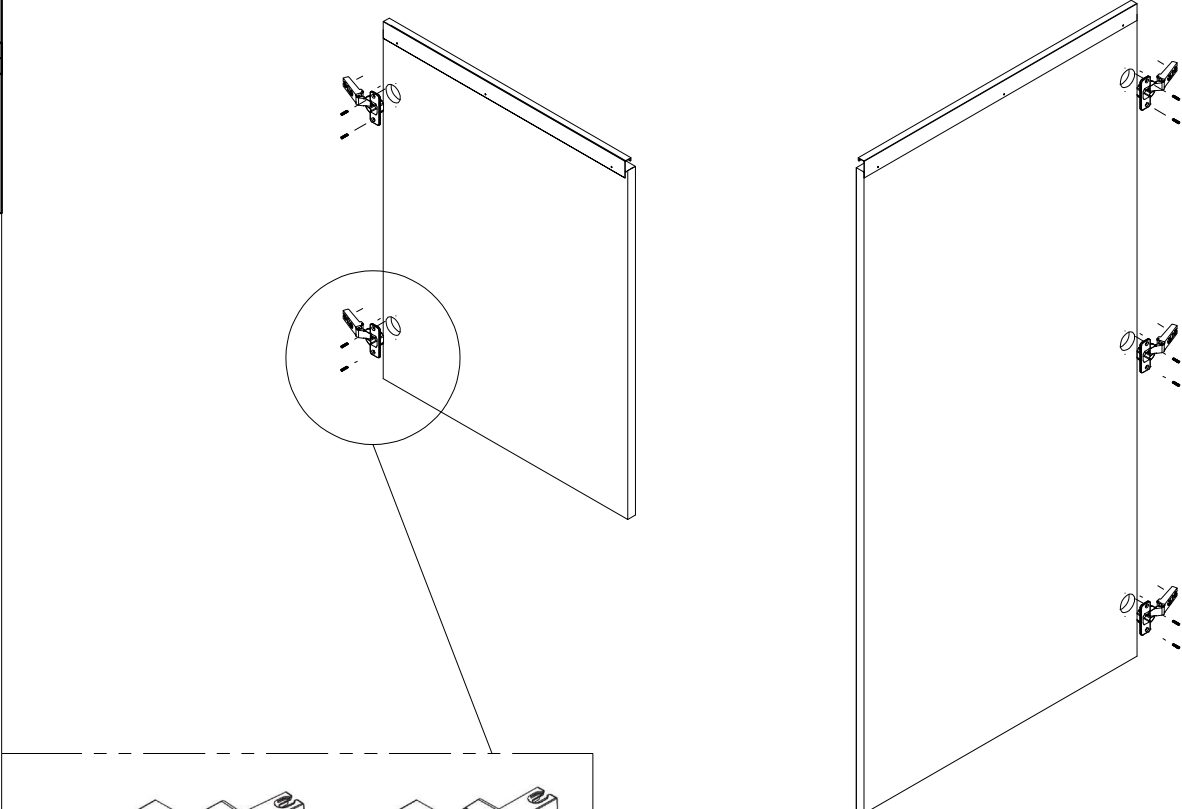

4 INR



FFPAR1050

1 INR

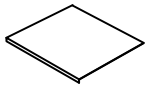

9WXXAPFA601

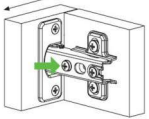
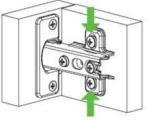
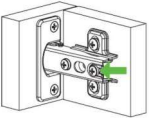
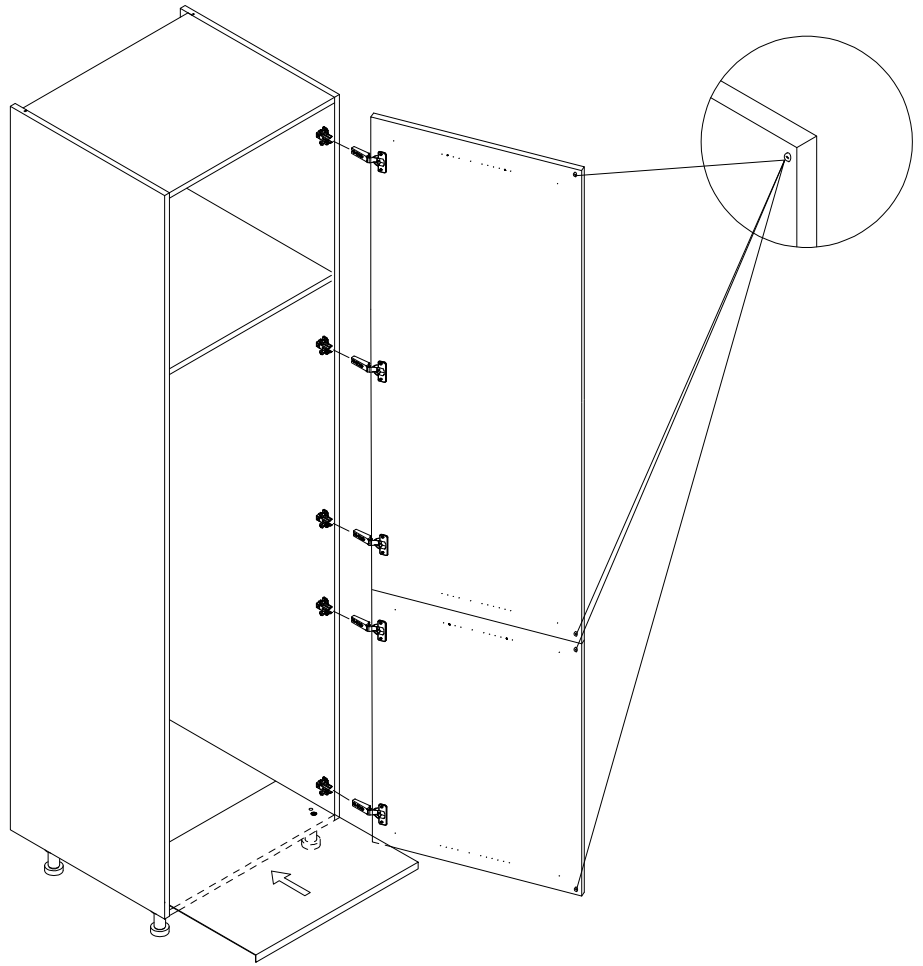

6 INR



5SIFA2000

4 INR



FFMON2018

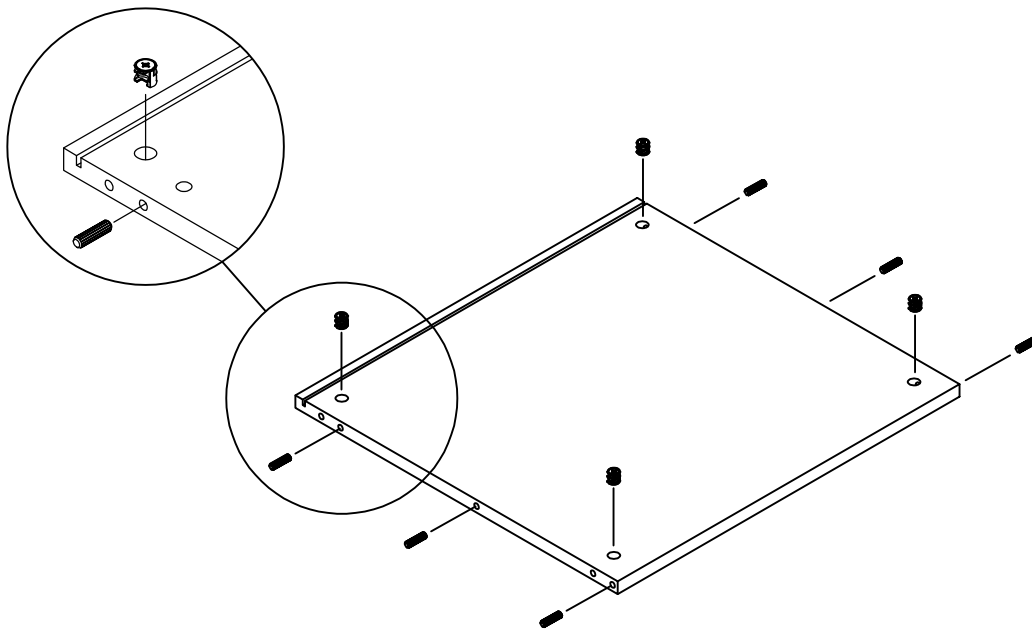

6 INR



5SIFA2000

4 INR

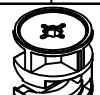

FFMON2018

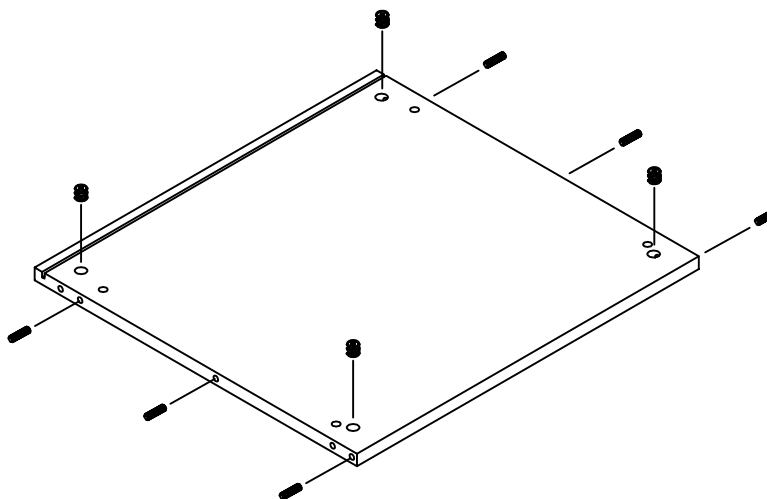

6 INR



5SIFA2000

4 INR



FFMON2018

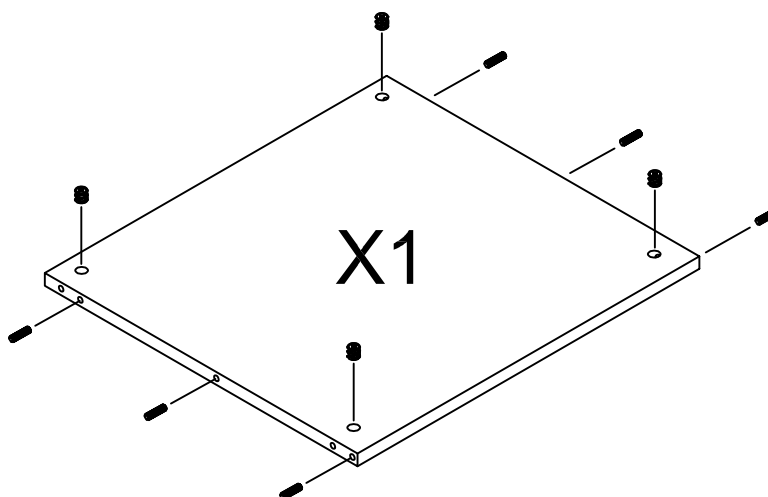

12 INR

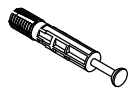

FFMON2051

4 INR

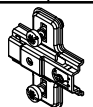

FFBMP2007

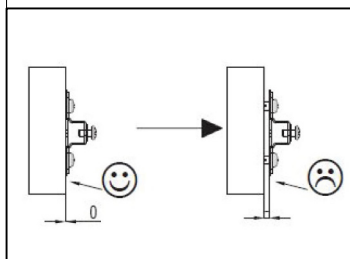
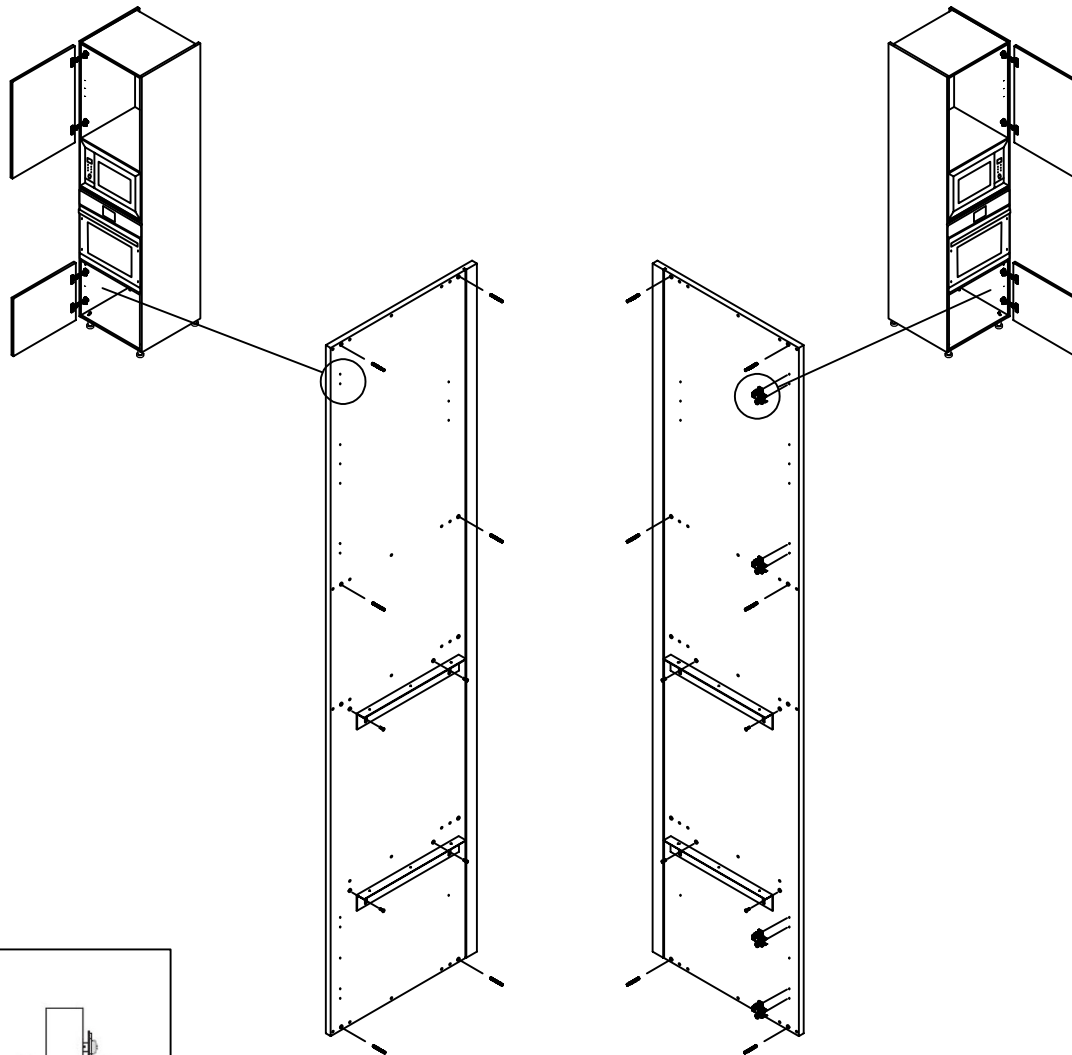

8 INR



FFVAN2056
3.5X15

4 INR

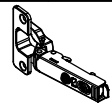

FFCPO2010

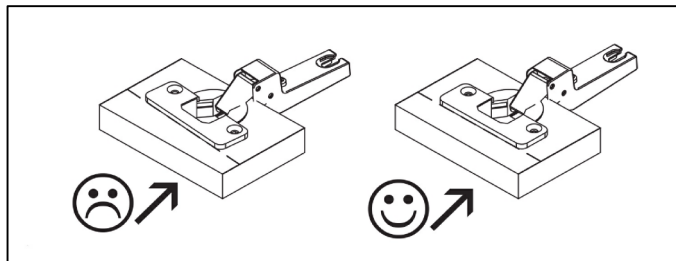
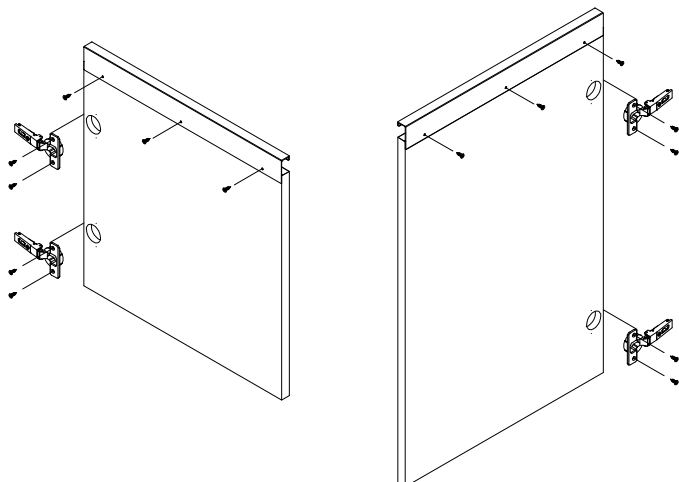

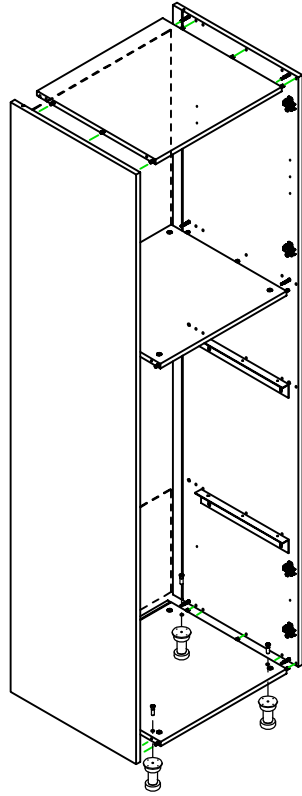
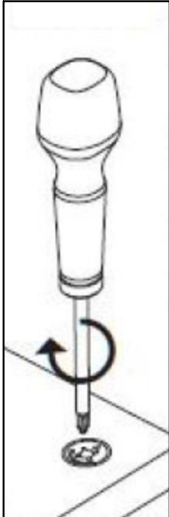

14 INR



FFFSZ2007

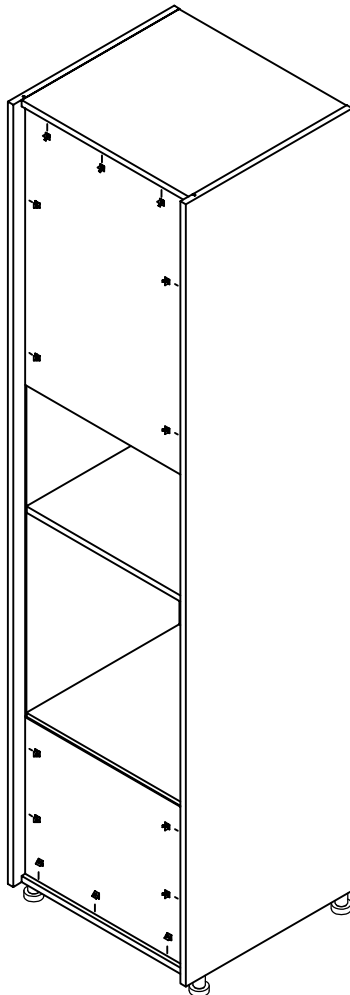

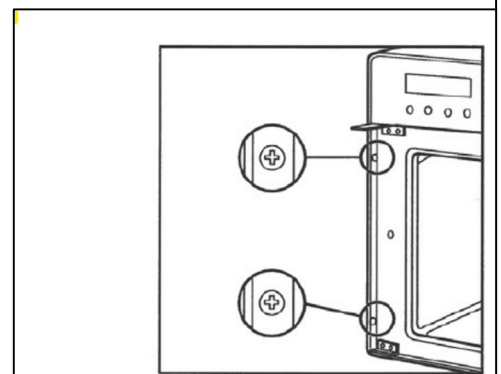
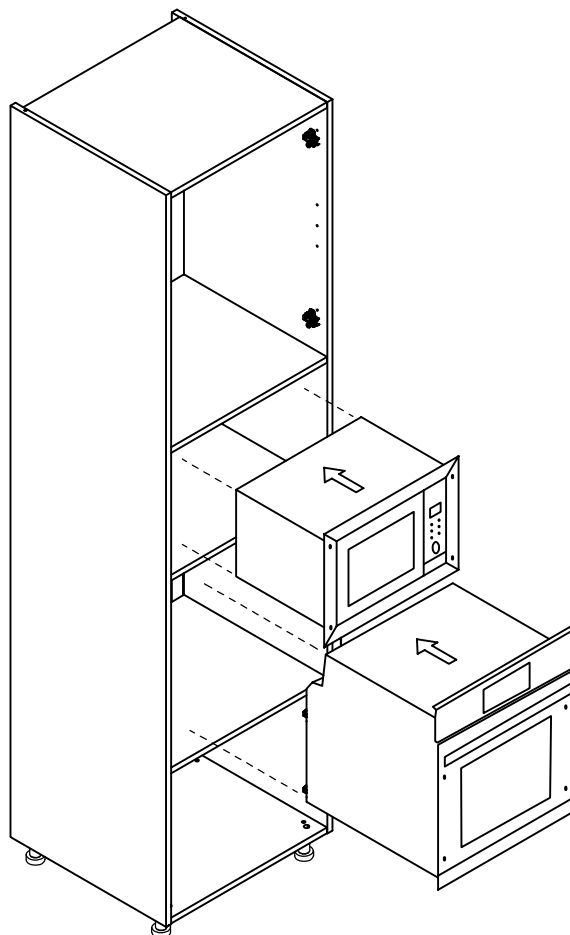
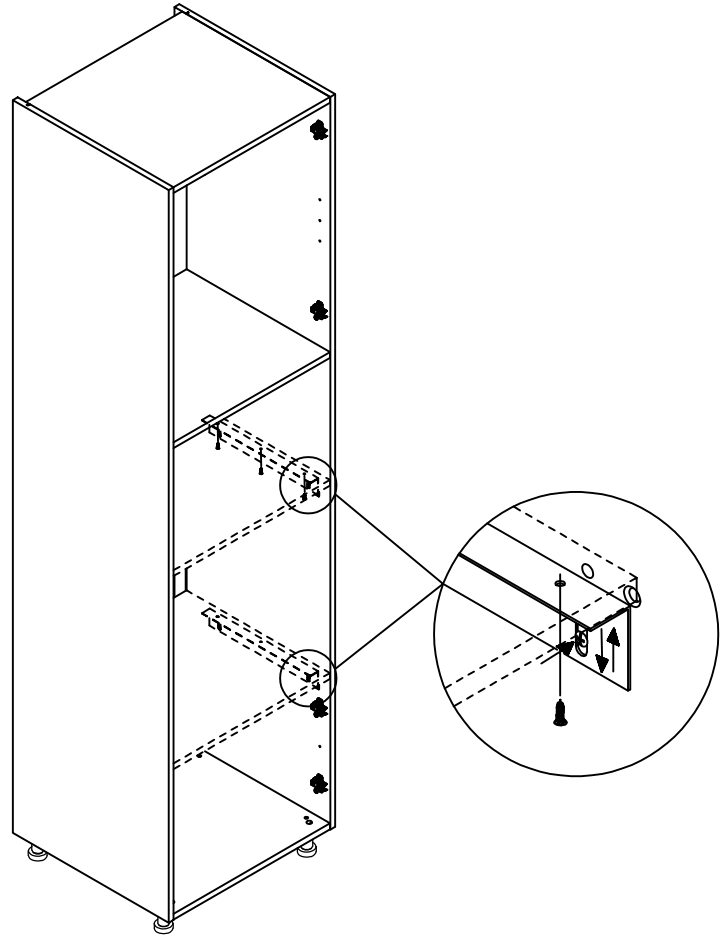

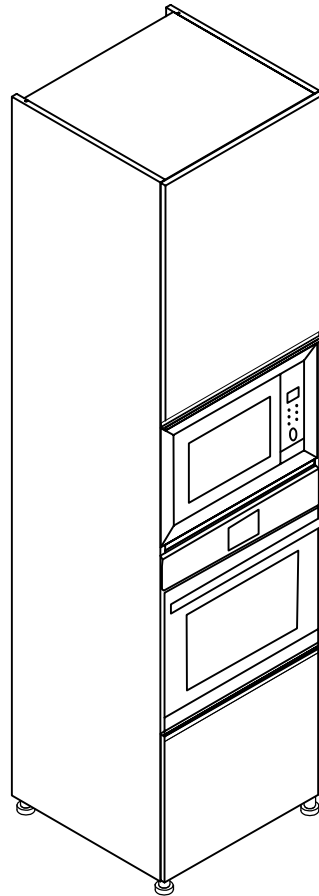
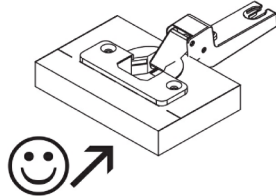
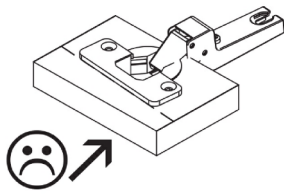
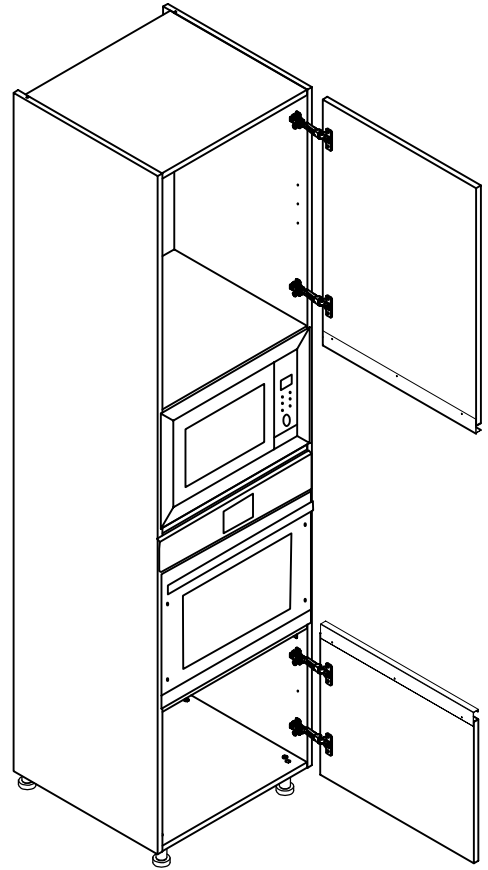

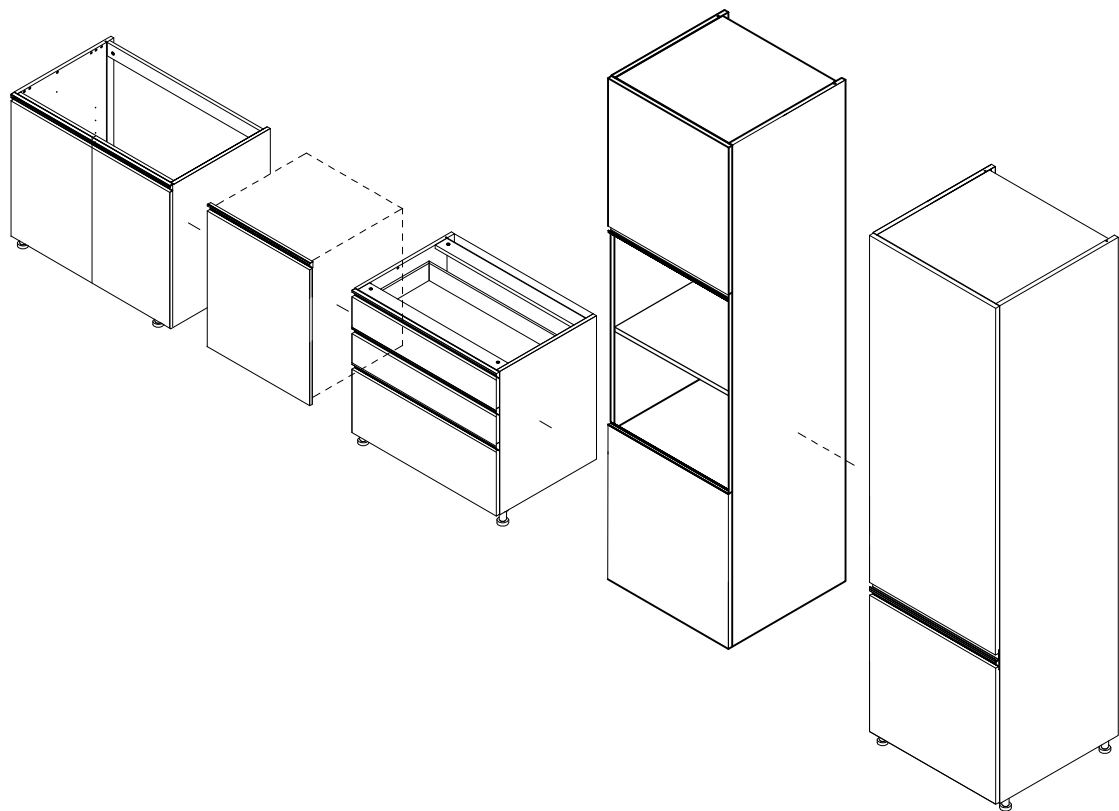

X 4 INR

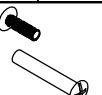

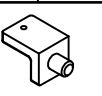

FFGPN2226

X 8 INR

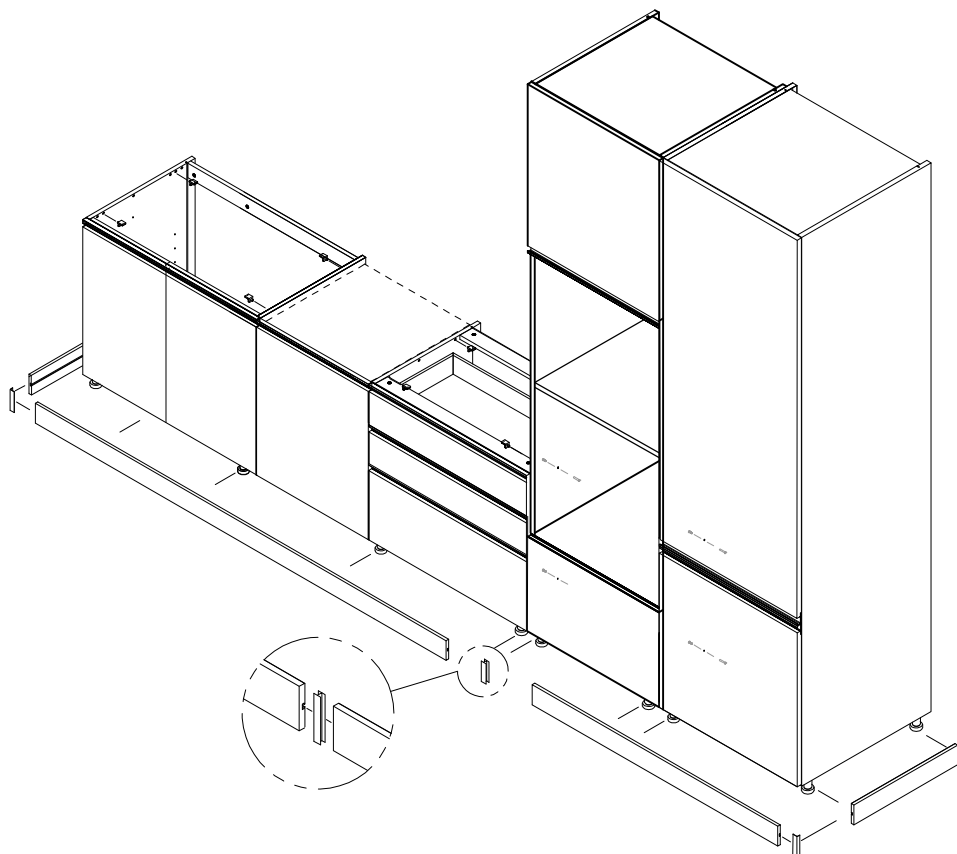
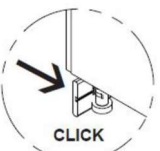
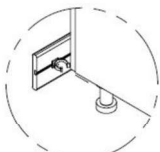
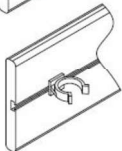
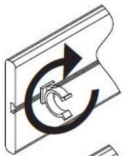

FFFPC2004



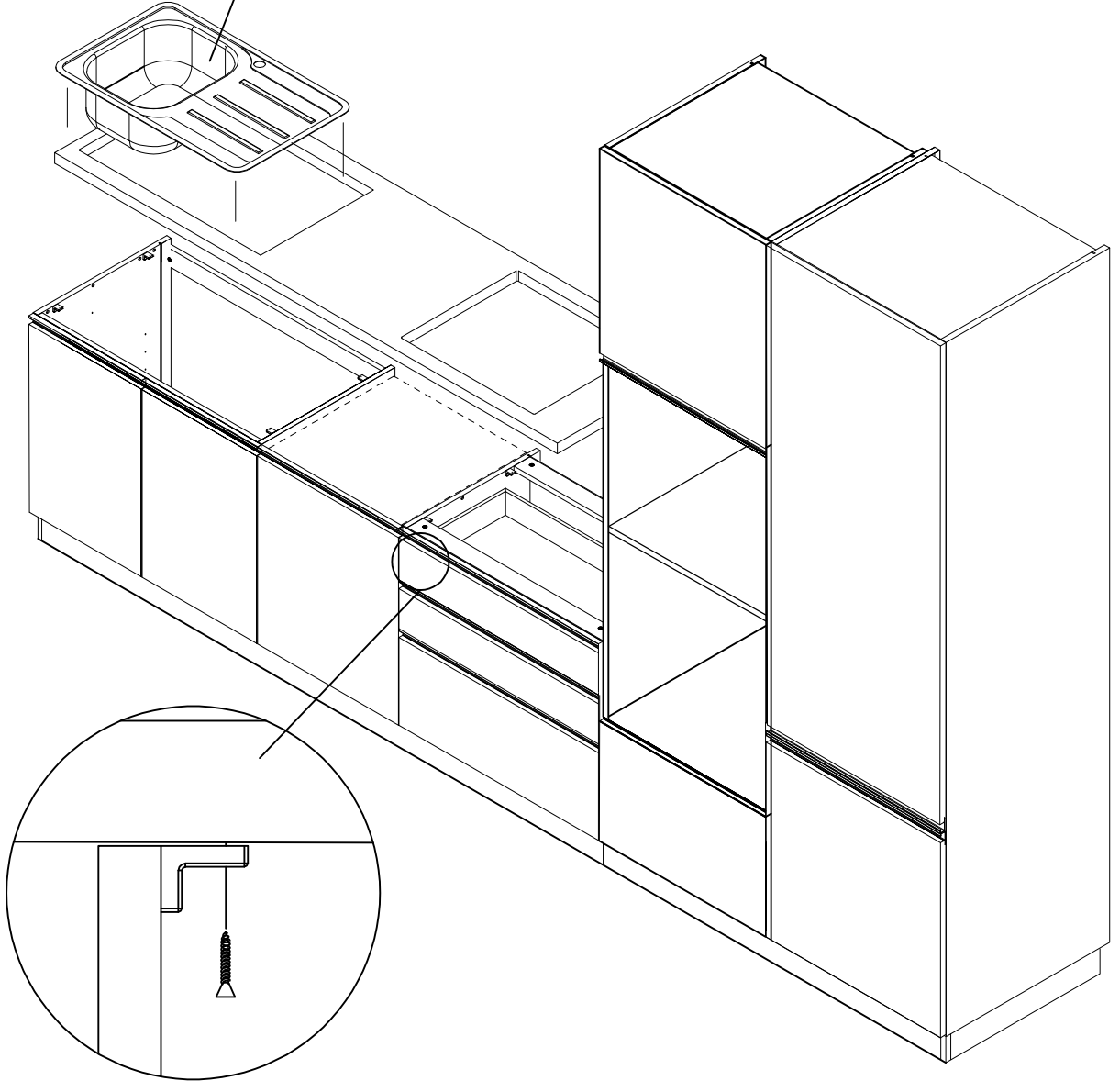
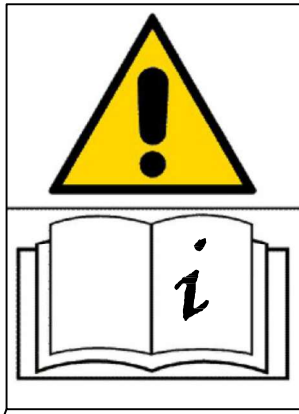

FFVAN2050
4x25

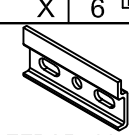
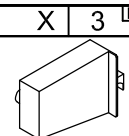
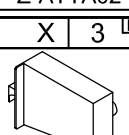

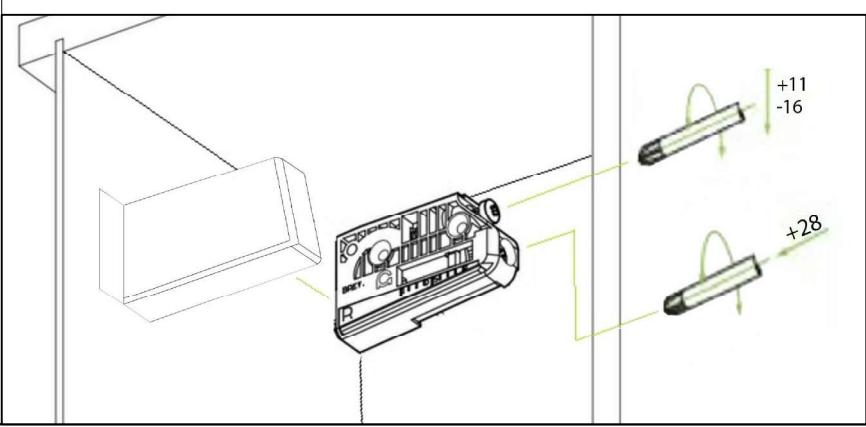
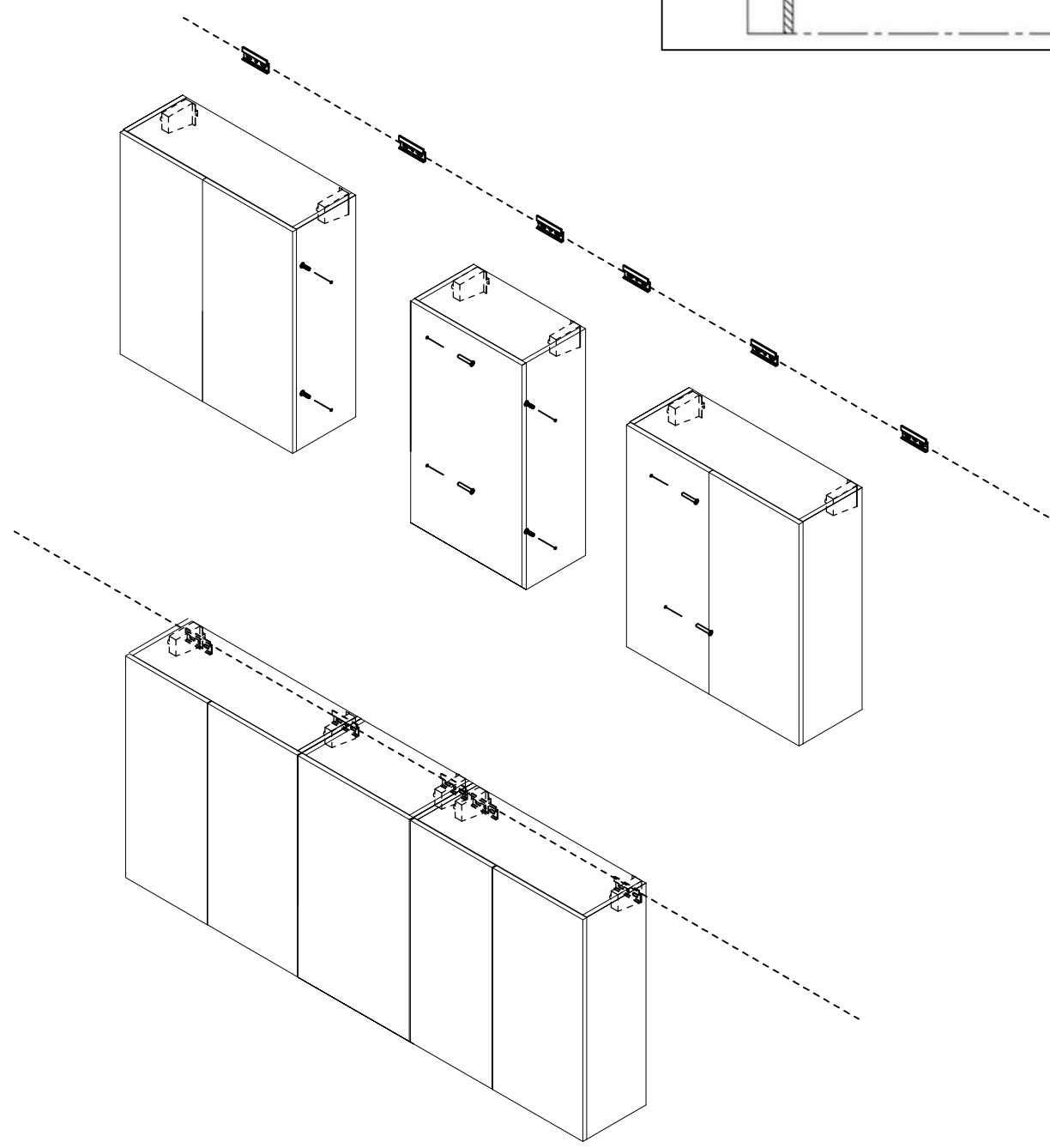
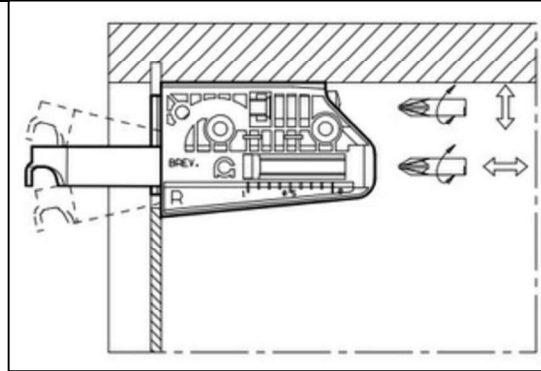
X	4	NR
 FFGPN2226		
X	6	NR
 FFBAR5007		
X	3	NR
 Z-ATTA02		
X	3	NR
 Z-ATTA01		

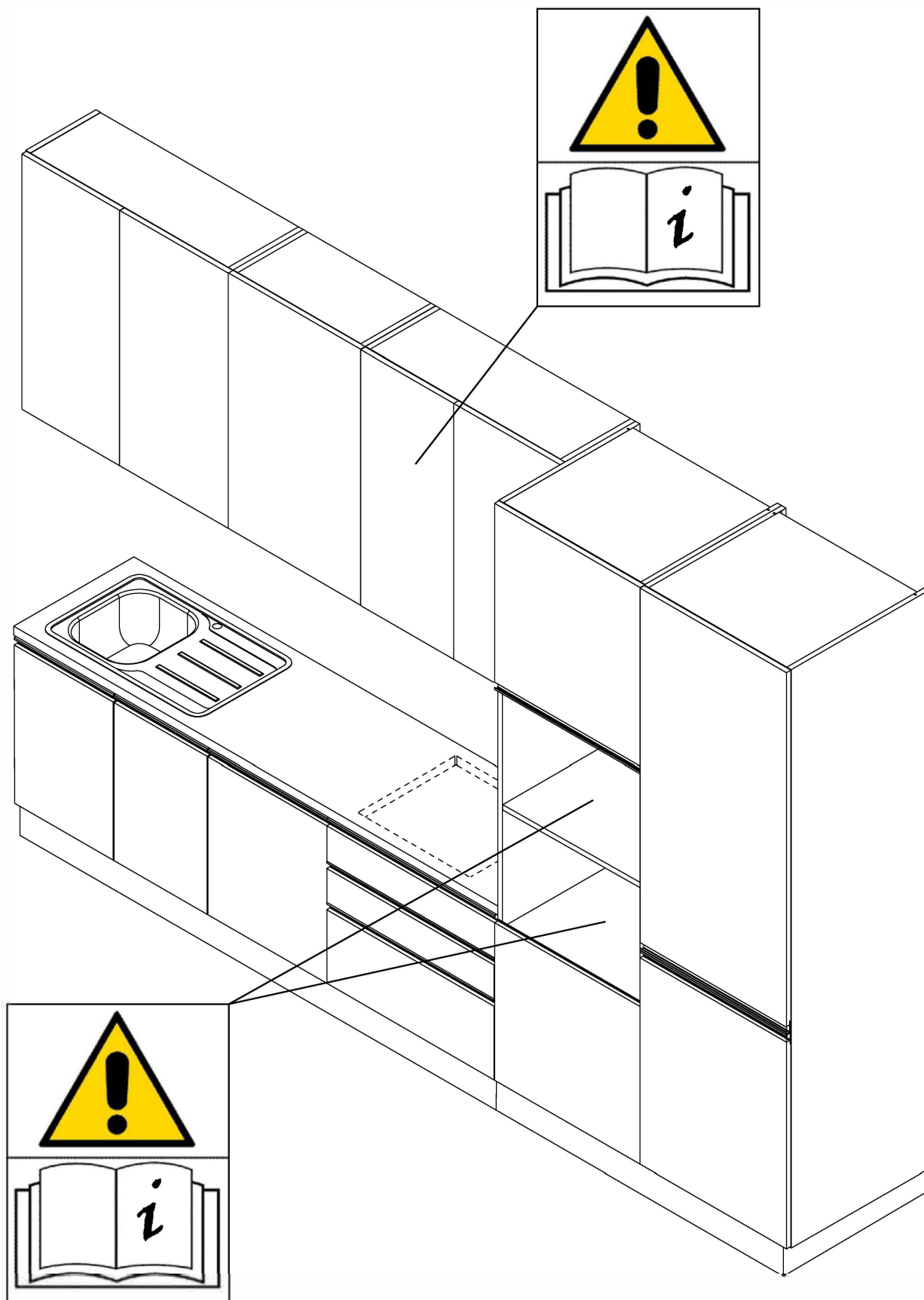



Candy ([Haier Europe](https://www.candy-home.com/hr))

- **Croatia** (Centar za pomoć / Servis): <https://www.candy-home.com/hr> HR/gdje-kupiti/
- **Slovenia** (Center za pomoč): <https://www.candy-home.com/sl> SI/kje-smo/
- **Romania** (Centru de asistentă): <https://www.candy-home.com/ro> RO/cere-asistenta/
- **Europa (Home)**: <https://www.haier-europe.com>

Beko

- **Romania** (Centru de asistentă): <https://www.beko.com/ro-ro/support/contact>
- **Croatia** (Korisnička podrška): <https://www.beko.com/hr-hr/support/help-center>
- **Serbia** (Korisnička podrška / Servisni centar): <https://www.beko.com/rs-sr/PodrSka/obratite-nam-se>